

BENITO

BENITO
–Urban
–Light
–Play
–Covers

–Urban

BENITO es heredera de una empresa centenaria de maquinaria de forja y fundición que se ha convertido en líder de la industria de equipamiento urbano global, con presencia en más de 50 países. Controla todas las fases del proceso productivo –diseño, fabricación, distribución y venta– y ofrece cuatro familias de productos, Urban (mobiliario urbano), Light (alumbrado público), Play (parques infantiles y equipamiento deportivo) y Covers (tapas y rejillas). Más de 6.000 referencias, 500 patentes y una filosofía de diseño más accesible y democrático que no renuncia a la calidad y la innovación para adecuar sus productos a las necesidades del mercado y de los usuarios. Desde 2001 BENITO posee la certificación ISO 9001, además de homologaciones específicas y certificaciones de calidad y técnicas para cada producto en diferentes países.

BENITO est l'héritière d'une entreprise centenaire de machinerie de forge et de fonte devenue leader de l'industrie de l'équipement urbain global, présent dans plus de 50 pays. Elle contrôle toutes les phases du processus de production (conception, fabrication, distribution et vente) et offre quatre familles de produits : Urban (mobilier urbain), Light (éclairage public), Play (aires de jeux et équipement sportif) et Covers (fonte de voirie). Plus de 6000 références, 500 brevets et une philosophie du design plus accessible et démocratique, qui ne renonce ni à la qualité, ni à l'innovation, afin d'adapter ses produits aux besoins du marché et des usagers. BENITO possède depuis 2001 la certification ISO 9001, en plus d'homologations spécifiques et de certificats de qualité et techniques pour chaque produit dans différents pays.

BENITO is the heir to a century-old machinery casting and forging business that has become a world leader in the urban equipment industry, present in more than 50 countries. It controls every phase of the production process – design, manufacture, distribution and sale – and offers four families of products: Urban (site furnishing), Light (street lighting), Play (playgrounds and sports equipment) and Covers (covers and grates). More than 6,000 catalogue items, 500 patents and an accessible and democratic design philosophy that upholds a commitment to quality and innovation in adapting its products to market and user needs. BENITO has been ISO 9001 certified since 2001 and holds specific approvals and quality and technical certificates for each of its products in different countries.



BENITO dispone de un Centro Operativo de 60.000m2 que alberga instalaciones de primer nivel, automatizado con los sistemas más avanzados en el ámbito logístico. La filosofía de trabajo se basa en el "lean warehousing", permitiendo la gestión de operaciones de gran envergadura, ofreciendo servicios inmediatos y plazos de entrega garantizados.

BENITO dispose d'un site opérationnel de 60 000 m2 hébergeant des installations de premier ordre et automatisé avec les systèmes les plus pointus dans le domaine de la logistique. Sa philosophie de travail repose sur le « lean warehousing », ce qui permet la gestion d'opérations de grande envergure, en proposant des services immédiats et des délais de livraison garantis.

BENITO has an Operating Centre occupying a surface area of 60,000m2, with first-class facilities and next-generation automated logistics systems. Its work philosophy is based on "lean warehousing", which makes it possible to manage large-scale operations, provide services immediately and guarantee delivery terms.





BENITO ha inaugurado recientemente un nuevo edificio de 1.800 m2 destinado a las oficinas centrales, dónde se centra toda la actividad comercial, financiera y de desarrollo, así como un espacioso showroom de 800m2 con una gran variedad de productos en exposición.

BENITO a récemment inauguré un nouveau bâtiment de 1 800 m2 destiné à son siège central, où se concentre toute l'activité commerciale, financière et de développement, ainsi qu'un espace showroom de 800 m2 pour exposer une grande variété de produits.

Recently, BENITO opened a new building covering 1,800 m2 for use as its head office, in which all the company's sales, financial and development activities will be based, in addition to a spacious 800m2 showroom with a large variety of products on show.

Oficinas Centrales | Siège central | Head Offices:

Barcelona: C/ Lleida 10 08500 Vic T. +34 938 521 000

Madrid: Avda. Manoteras 8 portal 4 bajo K 28050 T. 916 436 964

Delegaciones | Délégations | Branch offices:

EUROPE: France +33 0 468 210 992 Portugal +35 1 308 802 832 Italy +39 02 89877711 Romania +40 318 110 991 Poland +48 223 971 508 Russia +7 499 504 28 76

AMERICA: USA +1 617 778 29 47 Argentina +54 1 159 844 113 Chile +56 2 938 20 35 Mexico +52 5 546 319 722 Brazil +55 1 139 570 340 Peru +51 1707 1369

ASIA: China +86 1 063 705 530 Dubai +971 566 506 930 India +919 560 695 254



Centro Operativo | Site opérationnel | Operational Centre:

Naves 1-2 Logis Bages Onze de setembre 5-19

08650 Sallent Barcelona



feRRus

TRATAMIENTO DE PROTECCIÓN A LA CORROSIÓN DEL HIERRO

Proceso protector del hierro que garantiza una óptima resistencia a la corrosión.

TRAITEMENT DE PROTECTION CONTRE LA CORROSION DE L'ACIER

Processus protecteur de l'acier qui garantit une résistance optimale à la corrosion.

PROTECTION TREATMENT AGAINST IRON RUSTING

Which guarantees a high resistance to the rust conforming to the spray salt fog test.

1. Granallado

En esta fase se eliminan todo tipo de suciedades, oxidaciones, calamina, aceites etc.... en las que es necesario aplicar un tratamiento mecánico para eliminar las películas de óxido

2. Cataforesi

Se aplica un recubrimiento de pintura por inmersión utilizando corriente eléctrica para depositarla. Las partículas de pinturas son atraídas hacia la pieza y la pintura es depositada en ésta formando una capa uniforme.

3. Imprimación

Se aplica una imprimación en polvo epoxy con un alto contenido en zinc.

4. Pintura poliéster

Para terminar se aplica un revestimiento de pintura poliéster en polvo acabado color oxirón negro forja, obteniendo una doble función: estética y de protección.

1. Grenailage

Cette étape consiste en l'élimination de tous types de saleté, d'oxydation, de calamine, d'huile, etc., pour laquelle il est nécessaire d'appliquer un traitement mécanique afin d'éliminer les pellicules de rouille.

2. Cathaporsè

Cette technique consiste à plonger la pièce métallique dans un bain pour y déposer par électrolyse un revêtement de peinture. Les particules de peinture sont attirées par la pièce et la peinture se dépose sur celle-ci en formant une couche uniforme

3. Sous-couche

Application d'une sous-couche de poudre epoxy à haute teneur en zinc.

4. Peinture polyester

Pour terminer, on applique un revêtement de peinture polyester en poudre, finition couleur Oxiron noir forge, pour obtenir une double fonction : esthétique et protection.

1. Shot peening

During this phase, all dirt, rust, scale, oil, etc... is eliminated, these being operations in which the application of mechanical treatment is required to remove layers of rust.

2. Cathaphoresis

Application of a coat of paint by dipping, using an electric current to apply it. The paint particles are attracted to the part and the paint is deposited on it, forming an even layer.

3. Priming

Application of an Epoxy primer powder coat with a high zinc content.

4. Polyester paint

Application of a finishing coat of powder polyester paint in forge black Oxiron, with a double function: appearance and protection.

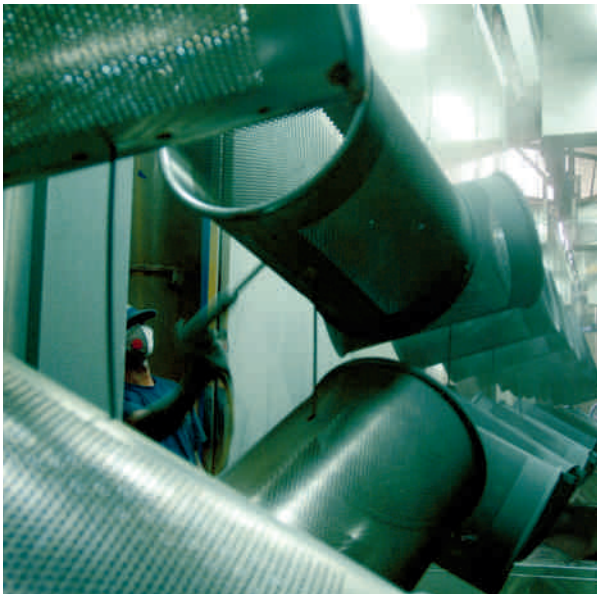



Proceso del tratamiento de la madera

Disponemos de unas instalaciones equipadas con la última tecnología en recubrimientos que garantizan el tratamiento más adecuado en función del tipo de material en el que se ha realizado el producto y el posterior uso del mismo.

Processus de traitement du bois

Nous disposons d'installations équipées d'une technologie dernière génération en revêtements, afin de garantir le traitement le plus adéquat en fonction du matériau de fabrication du produit et de son utilisation ultérieure.

Wood treatment process

We have facilities equipped with the latest technology in coatings that guarantee the most appropriate treatment, depending on the type of material used to make the product and the subsequent use given to it.



Protector decorativo para mobiliario urbano.

Aplicable para todo tipo de madera. El mobiliario urbano a mantener deberá estar limpio de polvo y suciedad, lijar suavemente la superficie de la madera.

Eliminar mediante lijado zonas agrisadas o muy deterioradas, para facilitar una buena penetración y adherencia del producto en la madera.

- Fácil aplicación
- Rápido secado
- Alta durabilidad
- Gran elasticidad y adherencia
- Protección eficaz
- Previene la formación de hongos
- Ausencia de olores
- Respeto al medio ambiente
- No inflamable

Protecteur décoratif pour mobilier urbain.

Aplicable à tous les types de bois. Le mobilier urbain devra être propre de poussière et de saleté, polir légèrement la surface du bois. Éliminer par polissage les zones grises ou très détériorées, afin de faciliter une bonne pénétration et adhérence du produit dans le bois.

- Application facile
- Séchage rapide
- Longue durée
- Grande élasticité et adhérence
- Protection efficace
- Préviens la formation de mousses
- Sans odeur
- Respecte l'environnement
- Non inflammable

Decorative protector painting to be applied to urban furniture.

It is suitable for all types of wood. First all dirt and dust has to be cleaned, then the wood surface needs to be sandpapered softly in order to smooth all the sharp edges and get a good absorption and adhesion level for the painting.

- Easy to apply
- Quick to dry
- High durability
- Strong elasticity and adherence
- Prevents fungal growth
- Odourless
- Environmental friendly
- Not inflammable



PIN01C-CAOBA
PIN01N-NATURAL



Acero corten

El Acero Corten es un tipo de acero realizado con una composición química que hace que su oxidación tenga unas características particulares que protegen la pieza frente a la corrosión atmosférica.

La oxidación del acero corten evoluciona con el paso del tiempo y se oxida, más o menos rápido, en función de la temperatura ambiente y la humedad.

El grado de exposición tiene gran influencia en el proceso de formación de la capa protectora. Si se ubica en un lugar expuesto directamente a la lluvia, al sol y al viento la capa de óxido se formará más rápidamente que si está protegido. En este último caso, el óxido tiende a ser más rugoso algo menos denso y menos uniforme. Los frecuentes cambio de humedad y secado son propicios para acelerar el proceso de resistencia a la intemperie. La contaminación atmosférica también tiene se efecto, por lo que en entornos industriales adquieren tonos más oscuros. En ambientes rurales el proceso es más lento y el óxido adquiere tonos más claros.

Acier corten

L'acier Corten est un type d'acier dont la composition chimique fait que son oxydation possède des caractéristiques particulières qui protègent la pièce contre la corrosion atmosphérique.

L'oxydation de l'acier Corten évolue avec le temps et la rouille se forme, plus ou moins vite, en fonction de la température ambiante et de l'humidité.

Le degré d'exposition influe grandement dans le processus de formation de la couche protectrice. S'il est exposé directement à la pluie, au soleil et au vent, la couche de rouille se formera plus rapidement que s'il est protégé. Dans ce dernier cas, la rouille tend à être plus rugueuse, un peu moins dense et moins uniforme. Les changements fréquents d'humidité et de séchage favorisent l'accélération du processus de résistance aux intempéries. La pollution atmosphérique influe également, ce qui explique que, dans les environnements industriels, la rouille prend des tonalités plus foncées. En atmosphères rurales, le processus est plus lent et la rouille prend des tonalités plus claires.

Corten Steel

Weathering (or Corten) steel has a chemical composition in which the rust forms a protective coating that protects the part from atmospheric corrosion.

Corten steel rust changes over time and the speed at which it rusts depends on ambient temperature and humidity.

The degree of exposure has an important effect on the formation of the protective coat. When placed in a site that is exposed to the rain, sun and wind, the rust layer will form more quickly than if it is protected. In the latter case, the rust will be rougher, less dense and less even. Frequent changes in humidity and drying are necessary, to accelerate the weathering process. Atmospheric contamination also plays a part, and for this reason, in industrial environments the tones are darker. In rural environments, the process is slower and the rust takes on a lighter tone.

Acero Inoxidable

Además de tener un aspecto siempre limpio, el acero inoxidable es un *material higiénico*, su composición permite que la suciedad y agentes externos como el polvo y las bacterias no queden adheridos a la superficie, *fácil de limpiar*, debido a la ausencia de porosidad en la superficie. Su durabilidad es uno de los mayores beneficios, debido a su resistencia a la corrosión y al paso del tiempo. Además, no se degradara al emplear productos de limpieza o al entrar en contacto con la humedad.

El acero inoxidable no es un revestimiento, esto hace que las cualidades sean las mismas siempre.

Por su superficie brillante, en arquitectura se utiliza muchas veces con fines decorativos, ya que a la atención cada vez mayor que se le da al carácter funcional del equipamiento urbano, se añade el interés de dotarlo de valores estéticos.

Acier Inoxidable

Présentant toujours un aspect propre, l'acier inoxydable est également un matériau hygiénique, sa composition faisant que la saleté et les agents externes tels que la poussière et les bactéries n'adhèrent pas à sa surface, et facile à nettoyer, étant donné l'absence de porosité sur sa surface. Sa durabilité est l'un de ses plus grands avantages, grâce à sa résistance à la corrosion et au passage du temps. En outre, il ne se dégrade pas lorsqu'on le nettoie avec des détergents ou lorsqu'il entre en contact avec l'humidité.

L'acier inoxydable n'est pas un revêtement, ainsi ses qualités sont toujours inaltérables.

Sa surface brillante fait qu'il est très souvent utilisé en architecture à des fins décoratives, puisqu'à l'importance croissante accordée à la fonctionnalité de l'infrastructure urbaine s'ajoute l'intérêt de la doter de valeurs esthétiques.

Stainless Steel

Apart from always having a clean appearance, stainless steel is a hygienic material. Its composition prevents external agents such as dust and bacteria from adhering to the surface and it is easy to clean, since its surface is non-porous. Its durability is one of its main advantages, due to its resistance to corrosion and to the passage of time. Furthermore, it will not be degraded when exposed to cleaning products or when it comes into contact with humidity.

Stainless steel is not a coating, and this means its properties always remain intact.

Due to its brilliant surface, it is often used in architecture for decorative purposes, as apart from the fact that more and more attention is now paid to the functional aspect of urban fixtures, there is an interest in giving them an attractive appearance.





Madera de pino tratada

Madera blanda, susceptible de ser atacada por elementos xilófagos, por eso hay que tratarla frente al ataque de termitas, insectos y hongos de pudrición. Uno de los tratamientos más eficaces es el tratamiento autoclave. Consiste en introducir la madera en un autoclave cerrado herméticamente, donde primero se hace el vacío para eliminar el aire, el agua y las resinas de las células que forman la albura. Seguidamente se introduce en el poro abierto los vapores a alta presión de los diferentes productos químicos que protegerán la madera.

Se clasifica en cinco tipos de riesgo de menor a mayor:

Clase 1: Madera protegida de la intemperie y no expuesta a los agentes atmosféricos.

Clase 2: Madera expuesta ocasionalmente a la humedad, pero protegida de los agentes atmosféricos.

Clase 3: Madera para exterior sin contacto con el suelo y no protegidas de la intemperie.

Clase 4: Madera en contacto con el suelo o con agua dulce y expuesta a una humificación permanente.

Clase 5: La madera está en contacto permanente con el agua salada.

Pin traité

Bois tendre, susceptible d'être attaqué par des organismes xylophages, c'est pourquoi il doit être traité contre les termites, les insectes et les champignons de pourriture.

L'un des traitements les plus efficaces est le traitement en autoclave. Il consiste à introduire le bois dans l'autoclave hermétiquement fermé, où l'on fait d'abord le vide pour éliminer l'air, l'eau et les résines des cellules qui forment l'aubier. Ensuite, on introduit dans les pores ouverts les vapeurs à haute pression des différents produits chimiques qui protégeront le bois.

Il existe cinq classes de risques, du plus faible au plus fort :

Classe 1 : Bois protégé des intempéries et non exposé aux agents atmosphériques.

Classe 2 : Bois exposé occasionnellement à l'humidité, mais protégé des agents atmosphériques.

Classe 3 : Bois pour extérieur sans contact avec le sol et non protégé des intempéries.

Classe 4 : Bois en contact avec le sol ou avec de l'eau douce et exposé à une humidification permanente.

Classe 5 : Bois en contact permanent avec de l'eau salée.

Treated pine wood

This is a soft wood that is susceptible to attack by xylophagous pests and so it must be treated for protection from woodworm, insects and rotting fungi.

One of the most effective treatments is autoclave treatment. It consists of placing the wood in a hermetically-sealed autoclave where a vacuum is created to eliminate the air, water and resin from the cells that form the sapwood. Then vapour containing the different chemicals that protect the wood enters the open pores at a high pressure.

It is classified into five types of risk, from the lowest to the highest:

Class 1: Wood protected against outdoor conditions and not exposed to atmospheric agents.

Class 2: Wood occasionally exposed to the damp, but protected against atmospheric agents.

Class 3: Wood for outdoor use, not in contact with the ground and not protected against outdoor conditions.

Class 4: Wood in contact with the ground or with fresh water and permanently exposed to the damp.

Class 5: Wood in permanent contact with salt water.

liGnus

Madera tropical

Madera exótica, de procedencia de bosques tropicales (África, Asia y América). Son maderas muy resistentes a la intemperie y a la humedad. Sus propiedades físico-mecánicas las hacen adecuadas y resistentes al exterior sin necesidad de ningún tratamiento al vacío, tan solo mantenimientos superficiales, Lignus.

Bois tropical

Bois exotique, provenant de forêts tropicales (Afrique, Asie et Amérique). Ce sont des bois très résistants aux intempéries et à l'humidité. Leurs propriétés physiques et mécaniques leur permettent de résister à l'extérieur sans avoir à les traiter sous vide, des traitements de surface type Lignus étant suffisants.

Tropical Wood

Exotic wood, from tropical forests in Africa, Asia and South America. This type of wood is extremely resistant to outdoor conditions and to the damp.

Its physical-mechanical properties make it appropriate for outdoor use, and it requires no vacuum treatment, but only surface maintenance, Lignus.





COLOURS

La sensibilidad por el color y la textura, junto a su eficacia y rigor profesional, han convertido a Benito en un referente en el ámbito de la pintura industrial y en un motor de innovación dentro del sector del tratamiento de superficies.

Nuestros productos de mobiliario urbano están disponibles en un amplio abanico cromático que permite dotar el espacio público de una estética singular y exclusiva.

La sensibilité pour la couleur et la texture, ainsi que l'efficacité et la rigueur professionnelle, ont fait de Benitoun référent dans le monde de la peinture industrielle, et un moteur d'innovation dans le secteur du traitement des superficies.

Nois produits de mobilier urbain sont disponibles dans un large éventail chromatique qui permet de doter l'espace public d'une esthétique singulière et exclusive.

Sensitivity to colour and texture, together with efficiency and professionalism, have made benito a point of reference in the industrial paint sector and a drive of innovation in the field of surface treatments.

Our site furnishings products are available in a wide range of colour schemes to equip public spaces with a distinctive, exclusive look.



Marcajes personalizados que marcan la diferencia.

BENITO ofrecemos la posibilidad de personalizar el mobiliario urbano mediante marcajes personalizados que permiten potenciar la imagen corporativa de su empresa o entidad y marcar la diferencia.

Le marquage à vie fait toute la différence

BENITO offre la possibilité de personnaliser le mobilier urbain avec le logo et/ou le blason de votre entreprise ou de votre Mairie. Ces marquages personnalisés sont un support idéal de l'image de l'entreprise ou de la collectivité.

Customised marking that makes all the difference

At BENITO we offer the possibility of personalising street furniture by means of customised marking to highlight the corporate image of your business or institution and make all the difference.



Madera + (Acero - Fundición - Inox) | Bois + (Acier -Ductile - Inox) | Wood + (Steel - Ductile iron- Stainless steel)



Madera tratada | Bois traité | Trated wood



Hormigón | Béton prefabricado | Concrete



UM372
KUBE
P. 38-39

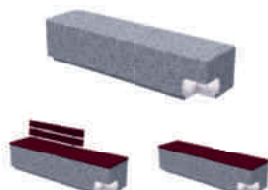

UM372L
KUBE LUZ
P. 40-41



UM372SK
KUBE KURVE
P. 42-43

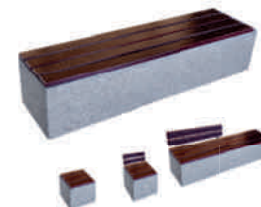

UM372LM
KUBE M
P. 44-45



UM396H
TRAU-H
P. 48



UM369
VOLGA
P. 49



UM371L
ELA / ELA MINI
P. 50-51



UM370
TOLEDO
P. 52-53

Acero | Acier | Steel



UM396E
TRAU
P. 46-47



UM392
CITY
P. 56-57



UM379M
ESSEN
P. 58-59



UM340
VALLES
P. 60-61



UM388E
FUNDICION
P. 62-63

Madera reciclada | Bois recyclé | Recycled wood



UM304NMTP - UM374MTP
EGUS TECHNICAL WOOD
P. 72



UM362K-C
ECOSENS
P. 73



UM337
REBNEW
P. 74-75

reBnew



Delta Finalist
ADI Awards
2016



GERMAN
DESIGN
AWARD
WINNER
2018

Citizen

By Eugeni Quitlet © © BENITO



Marcaje personalizado*
Marquages personnalisés*
Customised marking*

UM301S



UM301



UM301L

Pies de fundición dúctil con tratamiento Ferrus, proceso protector del hierro, que garantiza una óptima resistencia a la corrosión. Acabado imprimación epoxi y pintura poliéster en polvo color Marson. Cinco tablonces de sección 120 × 35 mm de madera tropical tratada con Lignus, protector fungicida, insecticida e hidrófugo. Acabado color Marson. Tornillos de acero inoxidable. Anclaje recomendado: Tornillos de fijación al suelo de M10 según superficie y proyecto.

Piètement en fonte ductile avec traitement Ferrus, procédé qui protège le fer et garantit une résistance optimale à la corrosion. Finition couche primaire époxy et thermolaquage polyester teinté Marson. Cinq lattes de bois tropical de section 120 × 35 mm traité avec Lignus, protecteur fongicide insecticide et hydrofuge. Finition teinté Marson. Vis en acier inoxydable. Ancrage recommandé: vis M10 pour la fixation au sol, en fonction de la surface et du projet.

Ductile iron legs treated with Ferrus, a protective process that guarantees high corrosion resistance. Epoxy primer coating and Marson polyester powder coated finish. Five tropical wood boards measuring 120 × 35 mm, treated with Lignus, a fungicide, insecticide and waterproofing agent. Marson color finish. Stainless steel bolts. Recommended anchoring: M10 bolts to anchor to the ground, depending on the surface and the project.

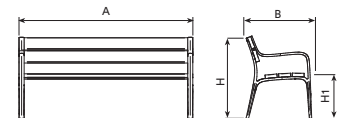
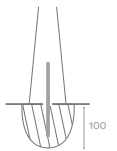

P.76-77

P.76-77

P.76-77

Otros productos Citizen
Autres produits Citizen
Other Citizen range products

Ref.	A	B	H	H1
UM301	1750 mm	650 mm	818 mm	450 mm
UM301S	700 mm	650 mm	818 mm	450 mm
UM301L	2400 mm	650 mm	818 mm	450 mm

*Opcional | En Option | Optional



Neobarcano

By BENITO © ©



UM304NS



UM304N



Marcaje personalizado*
Marquages personnalisés*
Customised marking*



UM304B



Pies de aluminio *
Pieds d'aluminium *
Aluminium legs available *



UM304NL



Pies de fundición dúctil con tratamiento Ferrus, proceso protector del hierro, que garantiza una óptima resistencia a la corrosión. Acabado imprimación epoxi y pintura poliéster en polvo color gris martelé. Seis tablonces de sección 110 x 35 mm de madera tropical tratada con Lignus, protector fungicida, insecticida e hidrófugo. Acabado color natural. Tornillos de acero inoxidable. Anclaje recomendado: Tornillos de fijación al suelo de M10 según superficie y proyecto. Opcional: Se puede suministrar en madera con certificado FSC, en madera técnica y polímero reciclado.

Piètement en fonte ductile avec traitement Ferrus, procédé qui protège le fer et garantit une résistance optimale à la corrosion. Finition couche primaire époxy et thermolaquage polyester gris martelé. Six lattes de bois tropical de section 110 x 35 mm traité avec Lignus, protecteur fongicide insecticide et hydrofuge. Finition teinte bois naturel. Vis en acier inoxydable. Ancrage recommandé : vis M10 pour la fixation au sol, en fonction de la surface et du projet. En option : bois certifié FSC ou en bois technique et polymère recyclé.

Ductile iron legs treated with Ferrus, a protective process that guarantees high corrosion resistance. Epoxy primer coating and grey martele polyester powder coated finish. Six tropical wood boards measuring 110 x 35 mm, treated with Lignus, a fungicide, insecticide and waterproofing agent. Natural colour finish. Stainless steel bolts. Recommended anchoring: M10 bolts to anchor to the ground, depending on the surface and the project. Optional: FSC certified wood or recycled polymer are alternatives finishes in which this bench that can be supplied.

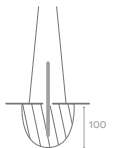
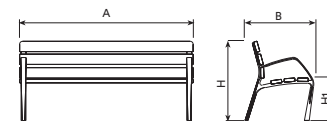

Ref.	A	B	H	H1	
UM304N	1800 mm	710 mm	800 mm	450 mm	✓
UM304NS	700 mm	710 mm	800 mm	450 mm	
UM304NL	3000 mm	710 mm	800 mm	450 mm	✓
UM304B	1800 mm	630 mm	655 mm	460 mm	✓

*Opcional | En Option | Optional





UM304K-C



UM304SK-C



Espacio reducido de almacenaje y ahorro en el transporte
 Espale réduit pour le stockage, économie dans le transport
 Save storage room and transport cost.

NeoKit

By BENITO © ©



Nueva formula Kit de fácil ensamblaje insitu. Ahorro en los costes de transporte y almacenaje. Fácil y cómodo ensamblaje directamente en la obra en el momento realmente oportuno.

Nouvelle formule "kit" avec un assemblage facil insitu. Economie sur le coût de transport et pour le stockage. Montage facile et pratique, directement sur le chantier.

New "kit" model for easy assembling on site. Save on transport and storage. Easy and comfortable, straight on site at the right time.



Fácil montaje, no se precisa herramientas especiales
 Montage facile, sans outils spéciaux
 Easy assembling proces. No tools are required

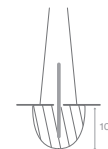
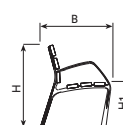
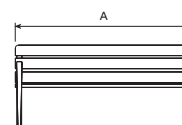

Ref.	A	B	H	H1
UM304K-C	1800 mm	710 mm	800 mm	425 mm
UM304SK-C	700 mm	710 mm	800 mm	425 mm

*Opcional | En Option | Optional





UM363WS



UM363W



UM363WL

Marcaje personalizado*
Marquages personnalisés*
Customised marking*



Delta XXI

By BENITO © ©

Pies de fundición dúctil con tratamiento Ferrus, proceso protector del hierro, que garantiza una óptima resistencia a la corrosión. Acabado imprimación epoxi y pintura poliéster en polvo color gris martelé. Tres tablones de sección 190 x 40 mm y uno de 130 x 40 mm de madera tropical tratada con Lignus, protector fungicida, insecticida e hidrófugo. Acabado color natural. Tornillos de acero inoxidable. Anclaje recomendado: Tornillos de fijación al suelo de M10 según superficie y proyecto. Opcional: Se puede suministrar en madera con certificado FSC.

Piètement en fonte ductile avec traitement Ferrus, procédé qui protège l'acier et garantit une résistance optimale à la corrosion. Finition couche primaire époxy et thermolaquage polyester gris martelé. Trois lattes de section 190 x 40 mm et une de 130 x 40 mm en bois tropical traité avec Lignus, protecteur fongicide, insecticide et hydrofuge. Finition teinte naturelle. Vis en acier inoxydable. Ancrage recommandé : vis M10 pour la fixation au sol, en fonction de la surface et du projet. En option : bois certifié FSC.

Ductile iron legs treated with Ferrus, a protective process for iron that guarantees high corrosion resistance. Epoxy primer coating and grey marteled polyester powder coated finish. Three tropical wood boards measuring 190 x 40 mm and one board measuring 130 x 40 mm, treated with Lignus, a fungicide, insecticide and waterproofing agent. Natural colour finish. Stainless steel bolts. Recommended anchoring: M10 bolts to anchor to the ground, depending on the surface and the project. Optional: FSC certified tropical wood can be supplied.

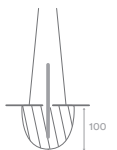
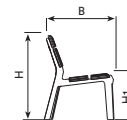
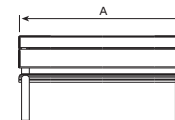

Ref.	A	B	H	H1	
UM363W	1700	685	835	455	✓
UM363WS	650	685	835	455	
UM363WL	3000	685	835	455	✓

*Opcional | En Option | Optional





Marcaje Personalizado*
Marquages personnalisés*
Customised marking*

UM377SM

Pies de acero Corten*
Piètements en acier Corten*
Corten Steel legs*



UM377M

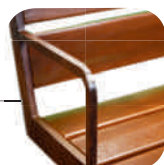

Con apoyabrazos*
Avec accoudoirs*
With armrest*

Quatro

By Carles Casamor y Marta Gabàs © BENITO



Pies de acero galvanizado con imprimacion epoxi y acabado en oxirón rojo óxido y cinco tablones de sección 140 x 70mm de madera tropical tratada con Lignus protector fungicida, insecticida e hidrófugo. Acabado en color natural. Tornillos de acero inoxidable. Anclaje recomendado: Tornillos de fijacion al suelo de M10 según superficie y proyecto. Opcional: Pies acero corten.

Piètement en acier avec une couche primaire époxy et finition en oxiron rouge oxyde et cinq lattes de section 140 x 70 mm en bois tropical traité avec Lignus, protecteur fongicide, insecticide et hydrofuge. Finition teinte naturelle. Vis en acier inoxydable. Ancreage recommandé: vis M10 pour la fixation au sol, en fonction de la surface et du projet. En option: Piètement en acier Corten.

Steel legs with epoxy primer coating and red wrought iron oxiron and 5 tropical wood boards measuring 140 x 70 mm, treated with Lignus, a fungicide, insecticide and waterproofing agent. Natural colour finish. Stainless steel bolts. Recommended anchoring: M10 bolts to anchor to the ground, depending on the surface and the project. Optional: Corten steel legs.

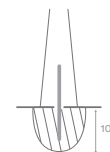
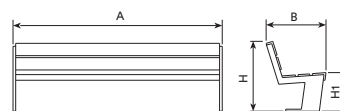

Ref.	A	B	H	H1
UM377M	2400 mm	635 mm	765 mm	450 mm
UM377SM	615 mm	635 mm	765 mm	450 mm

*Opcional | En Option | Optional



Marcaje personalizado*
Marquages personnalisés*
Customised marking*



UM374



UM374B

Otros productos Bretaña
Autres produits Bretaña
Other Bretaña range products



UM374MTP
EQUUS TECHNICAL WOOD
P. 72

Breña

Pies de fundición dúctil con acabado imprimación epoxy y pintura poliéster en polvo color negro forja. Tablones de sección 110x35 mm de madera tropical tratada con Lignus, protector fungicida, insecticida e hidrófugo. Acabado color caoba. Tornillos de acero inoxidable. Anclaje recomendado: Tornillos de fijación al suelo de M10 según superficie y proyecto. Opcional: Se puede suministrar en madera técnica.

Piètement en fonte ductile avec finition couche primaire époxy et thermolaquage polyester noir de forge. Lattes en bois tropical de section 110 x 35 mm, traité avec Lignus, protecteur fongicide, insecticide et hydrofuge. Finition teinte acajou. Vis en acier inoxydable. Ancrage recommandé : vis M10 pour la fixation au sol, en fonction de la surface et du projet.

Ductile iron legs with epoxy primer coating and black wrought iron coloured polyester powder coating. Tropical wood boards measuring 110 x 30 mm, treated with Lignus, a fungicide, insecticide and waterproofing agent. Mahogany colour finish. Stainless steel bolts. Recommended anchoring: M10 bolts to anchor to the ground, depending on the surface and the project. Optional: technical wood can be supplied.

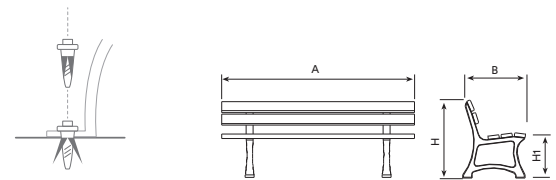

Ref.	A	B	H	H1
UM374	1800 mm	630 mm	770 mm	445 mm
UM374B	1800 mm	630 mm	-	445 mm

*Opcional | En Option | Optional



Madrid

Pies y refuerzo central de pletina de acero de 50 × 8 mm (UM332: 50 × 10 en las patas y 50 × 16 mm en los brazos) con esmalte negro en poliéster al horno. Dos tablones de madera tropical de 170 × 40 mm (UM332: 190 × 45 mm) en el asiento y un tablón de 190 × 40 mm (UM332: 245 × 45 mm) en el respaldo tratada con Lignus, protector fungicida, insecticida e hidrófugo. Acabado color caoba. Tornillos de acero inoxidable. Anclaje recomendado: Tornillos de fijación al suelo de M10 según superficie y proyecto.

Piètement et renfort central de plat en acier de 50 × 8 mm (UM332 : 50×10 pour les piètements et 50×16 pour les accoudoirs.) avec émail noir polyester au four. Deux lattes de bois tropical de 170 × 40 mm (UM332 : 190 × 45 mm) pour l'assise et une latte de 190 × 40 mm (UM332 : 245 × 45 mm) pour le dossier traité avec Lignus, protecteur fongicide, insecticide et hydrofuge. Finition teinte acajou. Vis en acier inoxydable. Ancrage recommandé: vis M10 pour la fixation au sol, en fonction de la surface et du projet.

Legs and center reinforcement made of a 50 × 8 mm (UM332:50×10mm supports and 50×16mm armrests) steel sheet with shiny black oven-baked polyester enamel. Two tropical wood boards measuring 170 × 40 mm (UM332: 190 × 45 mm) for the seat and a 190 × 40 mm (UM332: 245 × 45 mm) board for the backrest, treated with Lignus, a fungicide, insecticide and waterproofing agent. Mahogany colour finish. Stainless steel bolts. Recommended anchoring: M10 bolts to anchor to the ground, depending on the surface and the project.



UM330 



Marcaje personalizado*
Marquages personnalisés*
Customised marking*



UM332

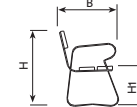
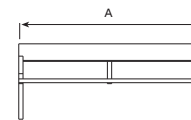

Ref.	A	B	H	H1	
UM330	2000 mm	655 mm	840 mm	450 mm	
UM332	2000 mm	654 mm	750 mm	388 mm	✓

*Opcional | En Option | Optional

Cantabrico

Pies de fundición dúctil con acabado imprimación epoxi y pintura poliéster en polvo color negro forja. Dos tabloncillos en el asiento de sección 150 x 45 mm y uno en el respaldo de sección 200 x 45 mm de madera tropical tratada con Lignus, protector fungicida, insecticida e hidrófugo. Acabado color caoba. Tornillos de acero inoxidable. Anclaje recomendado: Tornillos de fijación al suelo de M10 según superficie y proyecto.

Piètement en fonte ductile avec avec finition couche primaire époxy et thermolaquage polyester noir de forge. Siège en deux lattes de section 140 x 70 mm et dossier en une latte de section 200 x 45 mm en bois tropical traité avec Lignus, protecteur fongicide, insecticide et hydrofuge. Finition teinte acajou. Vis en acier inoxydable. Ancrage recommandé : vis M10 pour la fixation au sol, en fonction de la surface et du projet.

Ductile iron legs with epoxy primer coating and black wrought iron coloured polyester powder coated finish. Two tropical wood boards measuring 150 x 75 mm on the seat and one measuring 200 x 45 mm on the backrest, treated with Lignus, a fungicide, insecticide and waterproofing agent. Mahogany colour finish. Stainless steel bolts. Recommended anchoring: M10 bolts to anchor to the ground, depending on the surface and the project.



UM381

Marcaje personalizado*
Marquages personnalisés*
Customised marking*

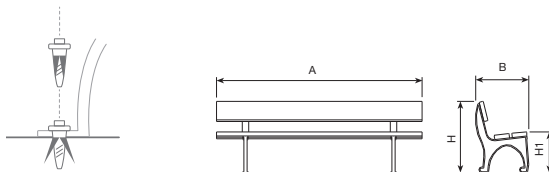

Ref.	A	B	H	H1
UM381	2000 mm	505 mm	700 mm	400 mm

*Opcional | En Option | Optional



Leman

By J.Descombes, C. López, Compagnies Desrues © BENITO



Sin apoyabrazos*
Sans accoudoirs*
Without armrest*
UM397W / UM397SW

UM397S



UM397



UM397B



Pies de fundición dúctil, con tratamiento Ferrus, proceso protector del hierro que garantiza una óptima resistencia a la corrosión. Acabado imprimación epoxi y pintura poliéster en polvo color gris. Bajo demanda se puede suministrar con pies de fundición de aluminio AG3. Tablones de sección 55 x 30 mm de madera tropical tratada con Lignus, protector fungicida, insecticida e hidrófugo. Acabado color caoba. Tornillos de acero inoxidable. Anclaje recomendado: Tornillos de fijación al suelo de M10 según superficie y proyecto. Opcional: Se puede suministrar en madera con certificado FSC / Sin apoyabrazos.

Piètement en fonte ductile, avec traitement Ferrus, procédé qui protège le fer et garantit une résistance optimale à la corrosion. Finition couche primaire époxy et thermolaquage, couleur gris. En option : piètement en fonte d'aluminium AG3. Lattes de section 55 x 30 mm en bois tropical traité avec Lignus, protecteur fongicide, insecticide et hydrofuge. Finition teinte acajou. Vis en acier inoxydable. Ancrage recommandé : vis M10 pour la fixation au sol, en fonction de la surface et du projet. En option : bois certifié FSC ou en bois d'ingénierie.

Ductile iron legs treated with Ferrus, a protective process for iron that guarantees high corrosion resistance. Epoxy primer coating and grey polyester powder coated finish. AG3 cast aluminium legs can be supplied upon request. Tropical wood boards measuring 55 x 30 mm, treated with Lignus, a fungicide, insecticide and waterproofing agent. Mahogany colour finish. Stainless steel bolts. Recommended anchoring: M10 bolts to anchor to the ground, depending on the surface and the project. Optional: FSC certified or technical wood can be supplied.

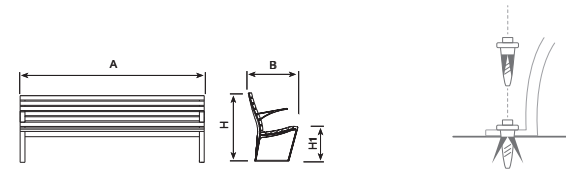

UM397M



UM397SE | UM397SEAL* | UM397E | UM397EAL* | UM397BE | UM397BEAL
Con listones de 52 x40 | Avec lattes de 52x40 | With 52x40 slats

Ref.	A	B	H	H1
UM397	2300 mm	600 mm	830 mm	420 mm
UM397B	2300 mm	545 mm	450 mm	
UM397S	650 mm	600 mm	830 mm	420 mm
UM397M	2300 mm	850 mm	750 mm	
UM397E/UM397EAL	1965 mm	600 mm	830 mm	430 mm
UM397BE / UM397BEAL	1965 mm	545 mm	460mm	
UM397SE/UM397SEAL	650 mm	600 mm	830 mm	430 mm

*Opcional | En Option | Optional

DESCOBREIX
EL FUTUR
GLÒRIES



Roda



UM320S

Pies de fundición dúctil con tratamiento Ferrus, proceso protector del hierro, que garantiza una óptima resistencia a la corrosión. Acabado imprimación epoxi y pintura poliéster en polvo color negro forja. Diez tablones de sección 52 x 40 mm de madera tropical tratada con Lignus, protector fungicida, insecticida e hidrófugo. Acabado color caoba. Tres barras de fijación y tornillos de acero inoxidable. Anclaje recomendado: Tornillos de fijación al suelo de M10 según superficie y proyecto.

Piètement en fonte ductile avec traitement Ferrus, procédé qui protège l'acier et garantit une résistance optimale à la corrosion. Finition couche primaire époxy et thermolaquage polyester noir de forge. Dix lattes de bois tropical de 52 x 40 mm traité avec Lignus, protecteur fongicide, insecticide et hydrofuge. Finition teinte acajou. Trois barres de fixation et vis en acier inoxydable. Ancrage recommandé : vis M10 pour la fixation, en fonction de la surface et du projet.

Ductile iron legs treated with Ferrus, a protective process for iron that guarantees high corrosion resistance. Epoxy primer coating and black wrought iron coloured polyester powder coated finish. Ten tropical wood boards measuring 52 x 40 mm, treated with Lignus, a fungicide, insecticide and waterproofing agent. Mahogany colour finish. Three stainless steel cross pieces and bolts. Recommended anchoring: M10 bolts to anchor to the ground, depending on the surface and the project.



UM320

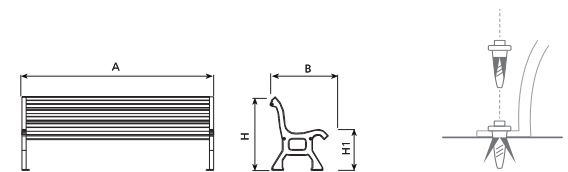

Ref.	A	B	H	H1
UM320	1995 mm	620 mm	750 mm	415 mm
UM320S	595 mm	620 mm	750 mm	415 mm

*Opcional | En Option | Optional



Ergo



UM368



Refuerzo central en el asiento*
Renfort special sur la banquette*
Reinforced metal band*



Marcaje personalizado*
Marquages personnalisés*
Customised marking*



UM368L

Pies de fundición dúctil con imprimación epoxi y pintura poliéster en polvo color negro forja. Seis tablones de sección 110x35 mm de madera tropical tratada con Lignus, protector fungicida, insecticida e hidrófugo. Acabado color caoba. Tornillos de acero inoxidable. Anclaje recomendado: Tornillos de fijación al suelo de M10 según superficie y proyecto.

Piètement en fonte ductile avec couche primaire époxy et thermolaquage polyester noir de forge. Six lattes de bois tropical traité avec Lignus, protecteur fongicide, insecticide et hydrofuge. Finition teinte acajou. Vis en acier inoxydable. Ancrage recommandé : vis M10 pour la fixation, en fonction de la surface et du projet.

Ductile iron legs with epoxy primer coating and black wrought iron coloured polyester powder coated finish. Six tropical wood boards measuring 110 x 35 mm, treated with Lignus, a fungicide, insecticide and waterproofing agent. Mahogany colour finish. Stainless steel bolts. Recommended anchoring: M10 bolts to anchor to the ground, depending on the surface and the project.

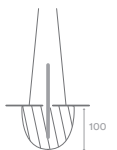
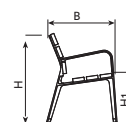
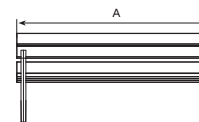

Ref.	A	B	H	H1
UM368	1800 mm	660 mm	830 mm	455 mm
UM368L	3000 mm	660 mm	830 mm	455 mm

*Opcional | En Option | Optional



Barcino



UM305S

Pies de fundición dúctil con acabado imprimación epoxi y pintura poliéster en polvo color negro forja. Tablones de sección 40 x 35 mm (UM302: 45 X 35mm) de madera tropical tratada con Lignus, protector fungicida, insecticida e hidrófugo. Acabado color caoba. Tornillos de acero inoxidable. Anclaje recomendado: Tornillos de fijación al suelo de M10 según superficie y proyecto. Opcional: Se puede suministrar madera con certificado FSC o PEFC.



UM305





Piètement en fonte ductile avec finition couche primaire époxy et thermolaquage polyester noir de forge. Lattes de bois tropical de section 40 x 35 mm (UM302: 45 X 35mm) traité avec Lignus protecteur fongicide, insecticide et hydrofuge. Finition teinte acajou. Vis en acier inoxydable. Ancrage recommandé : vis M10 pour la fixation au sol, en fonction de la surface et du projet. En option : bois certifié FSC ou PEFC.

Ductile iron legs with epoxy primer coating and black wrought iron coloured polyester powder coated finish. Tropical wood boards measuring 40 x 35 mm (UM302: 45 X 35mm) , treated with Lignus, a fungicide, insecticide and waterproofing agent. Mahogany colour finish. Stainless steel bolts. Recommended anchoring: M10 bolts to anchor to the ground, depending on the surface and the project. Optional: FSC- or PEFC-certified wood can be supplied.

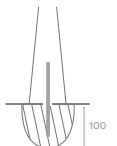
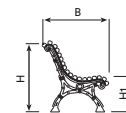
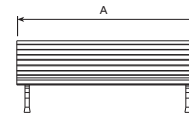

UM302



Ref.	A	B	H	H1	
UM305	2000 mm	700 mm	785 mm	440 mm	
UM305S	540 mm	700 mm	785 mm	440 mm	
UM302	2000 mm	700 mm	760 mm	405 mm	<input checked="" type="checkbox"/>

*Opcional | En Option | Optional



Kube



UM372S

Hormigón prefabricado color gris granítico de aspecto liso. Se puede colocar en elementos aislados o en grupos. Anclaje recomendado: Apoyado por su propio peso.

Béton préfabriqué gris granite, aspect lisse. Peut être placé séparément ou en groupes. Ancrage recommandé : posé à terre.

Pre-cast smooth granite grey concrete. May be positioned individually or in groups. Recommended anchoring: free-standing.



UM372

Otros productos Kube
Autres produits Kube
Other Kube range products



P.40-41

P.102

P.102

P.123

P.151

P.151

P.196

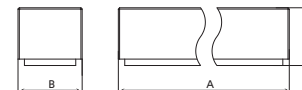

Ref.	A	B	H
UM372	2000 mm	500 mm	450 mm
UM372S	500 mm	500 mm	450 mm

*Opcional | En Option | Optional



Kube light



UM372L

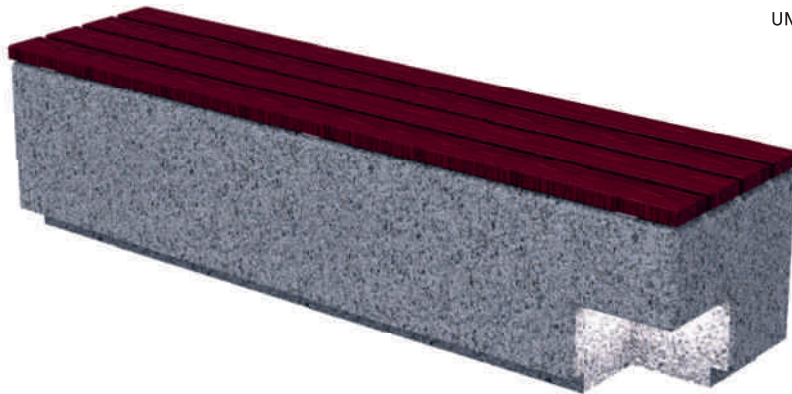

UM372LML

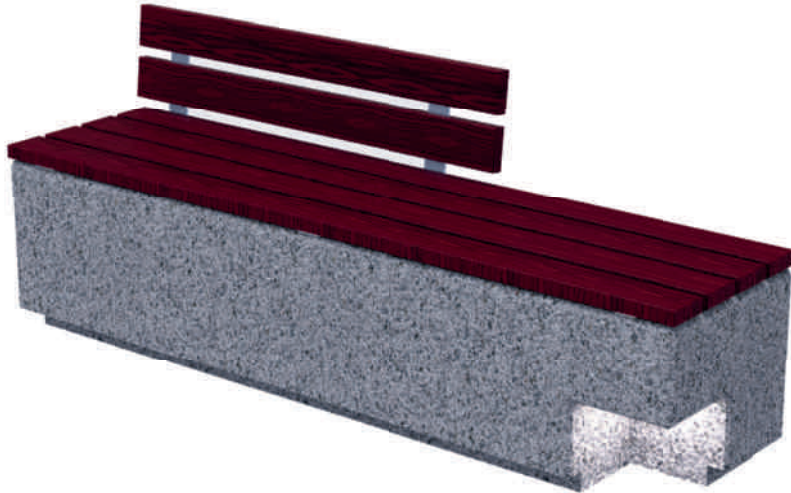

UM372LPL

Hormigón prefabricado color gris granítico de aspecto liso. Se puede colocar en elementos aislados o en grupos. Anclaje recomendado: Apoyado por su propio peso. Baliza empotrada en el banco, material cuerpo: aluminio, material del difusor: cristal matizado, acabado en acero inoxidable. Lámpara LED con potencia de 4,5W, alimentación de 220V-240V AC, equipo electrónico, Clase 1, IP:65, IK:09, temperatura de color: 3000k.

Béton préfabriqué gris granite, aspect lisse. Peut être placé séparément ou en groupes. Possibilité de placer les éléments isolés ou en groupe. Fixation recommandée: Par son propre poids. Balise encastrée dans le banc. Matériel carcasse: aluminium, matériel du diffuseur: verre mate, finition en acier inoxydable. Lampe LED avec puissance de 4,5W, alimentation de 220V-240V AC, équipement électronique, Classe I, IP:65, IK:09, température de couleur: 3000k.

Pre-cast smooth granite grey concrete. Designed to be both installed as a standalone product or in groups. Recommended anchoring: freestanding. Embedded Beacon within the bench. Body made of aluminium. Diffuser made of frosted glass. Stainless steel finish. LED lamp with a 4,5W output, input voltage 220V-240V AC, electronic control gear, Class I, IP65, IK09, colour temperature: 3000K.

Otros productos Kube
Autres produits Kube
Other Kube range products

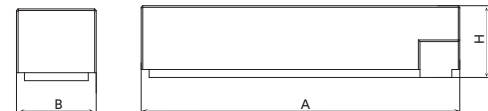
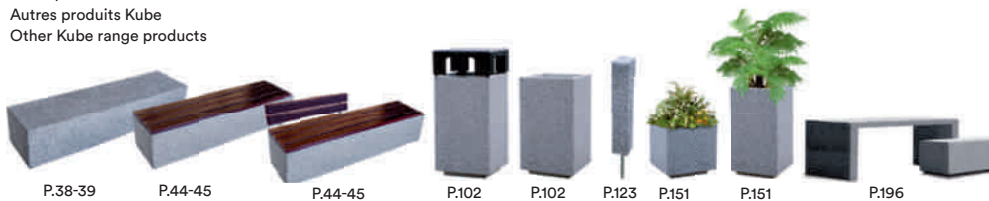

Ref.	A	B	H
UM372L	2000 mm	500 mm	450 mm
UM372LML	2000 mm	500 mm	775 mm
UM372LPL	2000 m	500 mm	490 mm

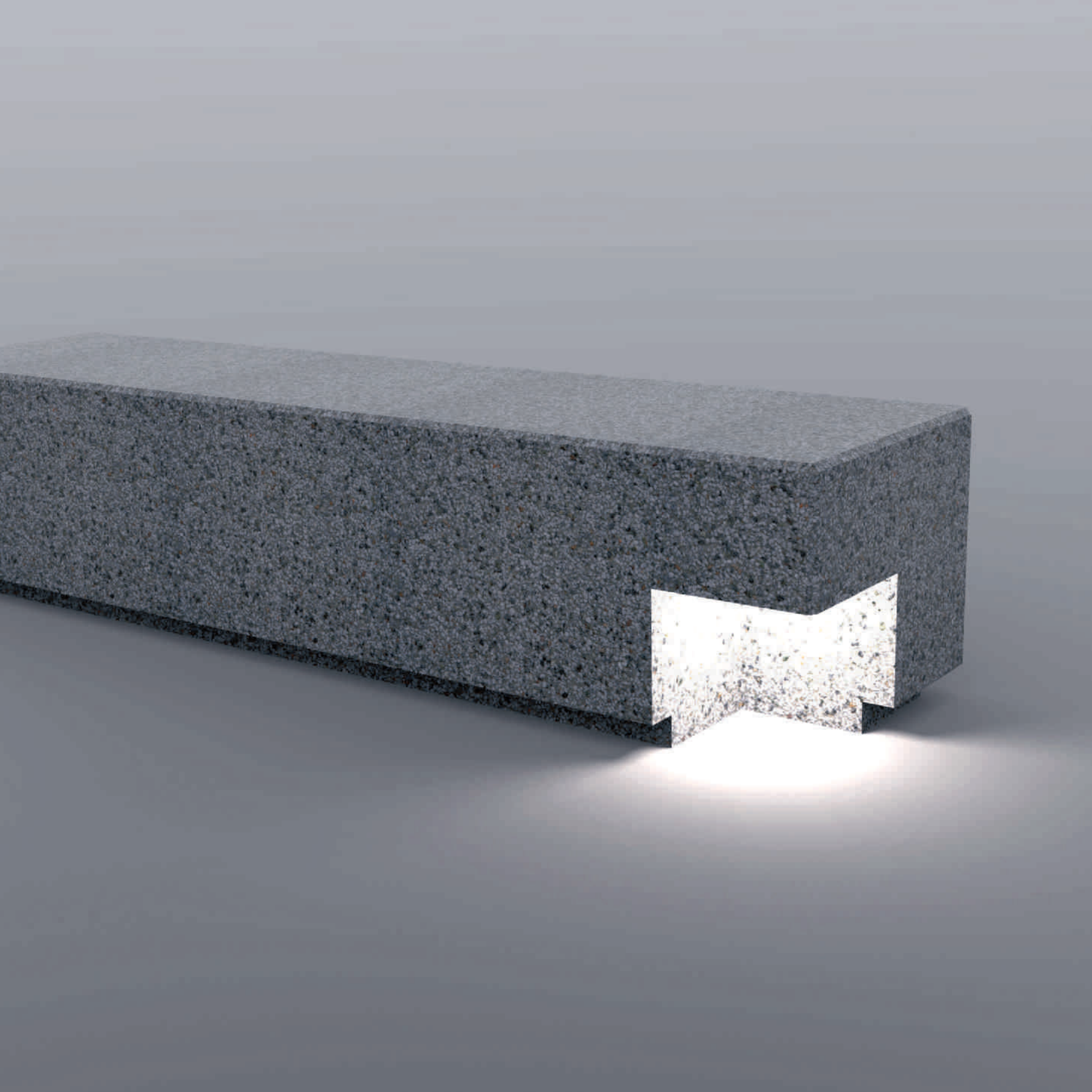



Kube Kurve

Hormigón prefabricado color gris granítico de aspecto liso. Se puede colocar en elementos aislados o en grupos. La combinación de asientos plantea un juego estético y ofrece la posibilidad de que estos se orienten en distintas direcciones. Anclaje recomendado: Apoyado por su propio peso.

Béton préfabriqué gris granite, aspect lisse. Possibilité de placer les éléments isolés ou en groupe. La combinaison d'assises offre un jeu esthétique et la possibilité d'orientation dans différentes directions. Ancrage recommandé : posé à terre.

Pre-cast smooth granite grey concrete. Designed to be both installed as a standalone product or in groups. The possible seating combination make for a nice aesthetic game and the items can be oriented to several different directions. Recommended anchoring: free-standing.



UM372SK

Otros productos Kube
Autres produits Kube
Other Kube range products

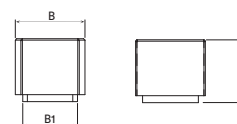

Ref.	A	B	B1	H
UM372SK	500 mm	498 mm	418 mm	450 mm

Kube Kurve

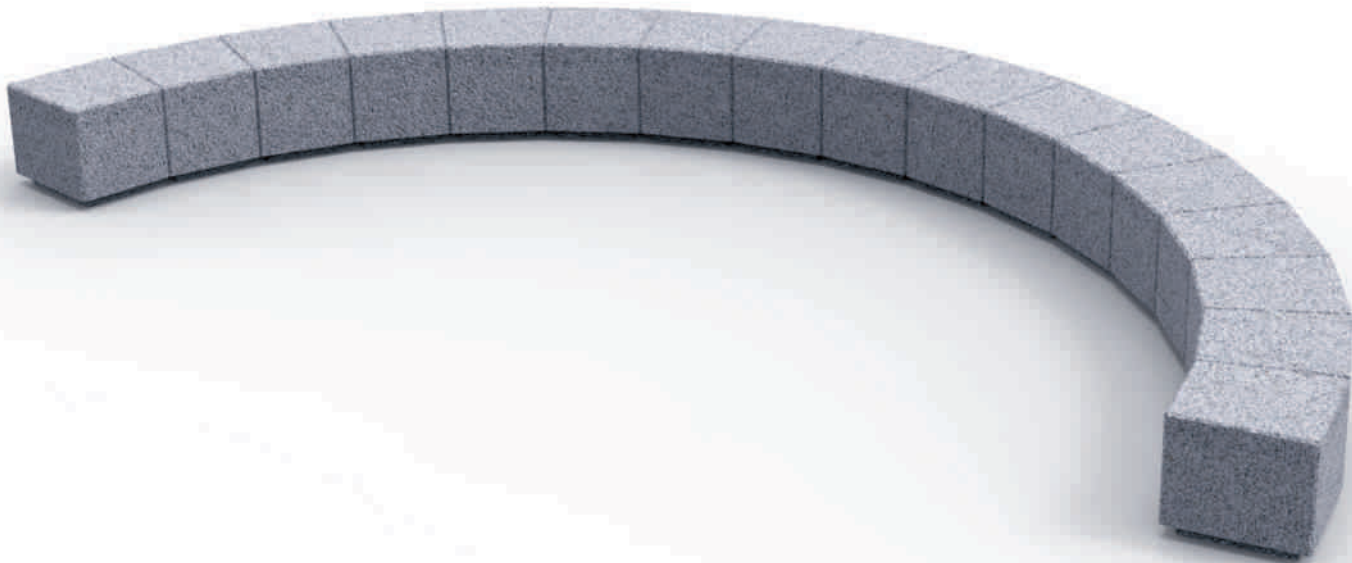
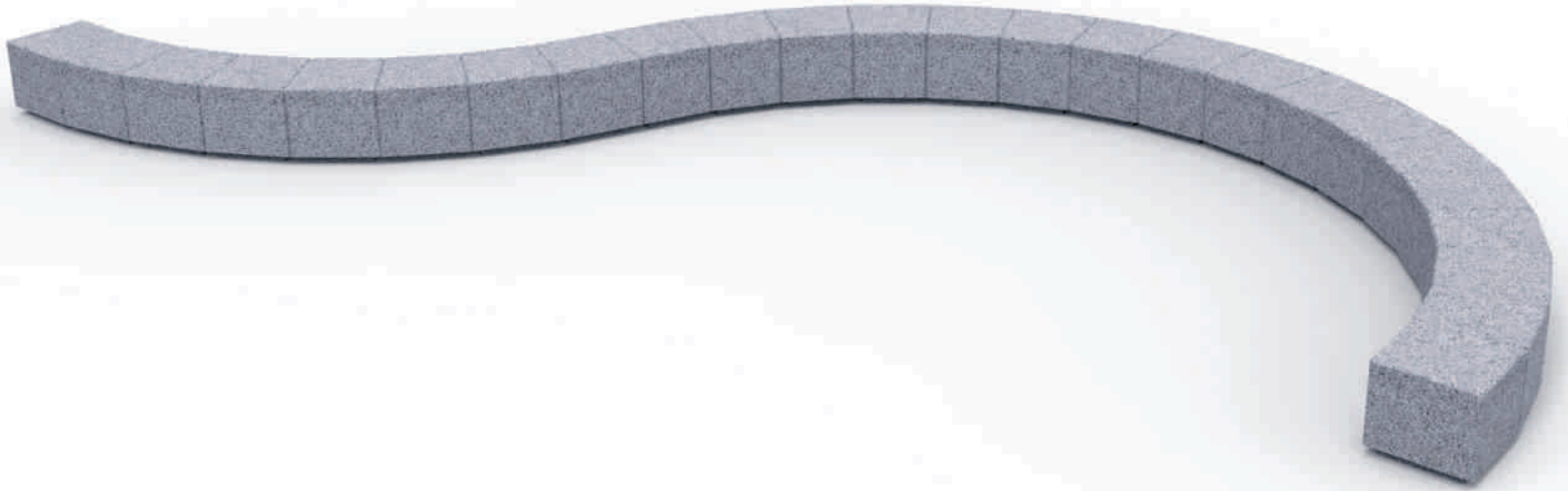

Kube M

Hormigón prefabricado color gris granítico de aspecto liso. Se puede colocar en elementos aislados o en grupos. Anclaje recomendado: Apoyado por su propio peso. Se combina con listones de madera tropical de sección 110×35mm, tratada con Lignus, protector fungicida, insecticida e hidrófugo. Acabado color caoba

Béton préfabriqué gris granite, aspect lisse. Peut être placé séparément ou en groupes. Ancrage recommandé : posé à terre. Combiner avec des lattes en bois tropical de section 110 × 35 mm, traité avec Lignus, protecteur fongicide, insecticide et hydrofuge. Finition teinte acajou

Pre-cast smooth granite grey concrete. May be positioned individually or in groups. Recommended anchoring: free-standing. This product be combined with 110 × 35 mm tropical wood slats, which have been treated with Lignus, a fungicide, insecticide and waterproofing agent. Mahogany colour finish



UM372SLP

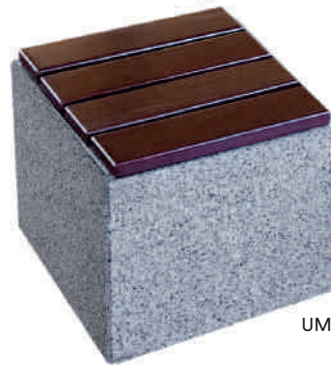

UM372SLM

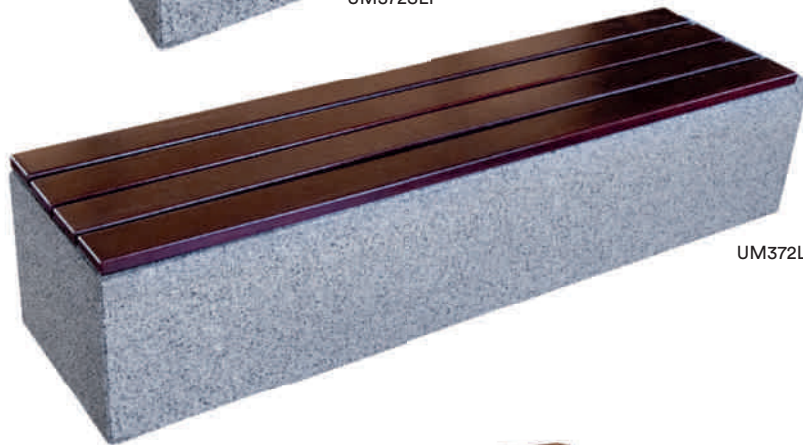

UM372LM

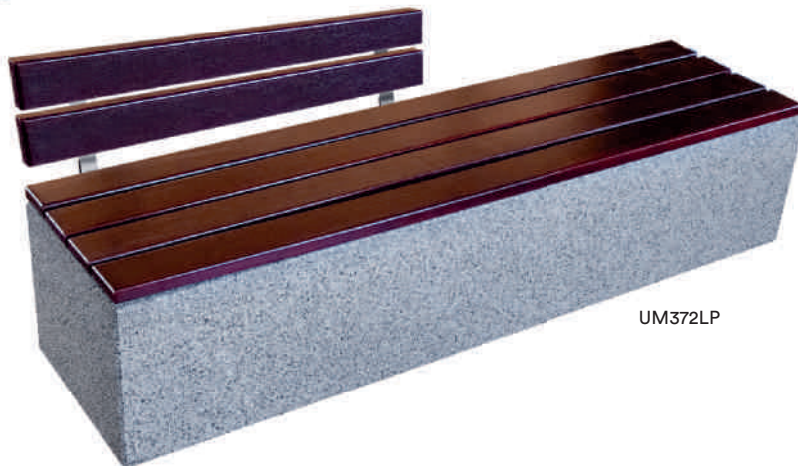

UM372LP

Otros productos Kube
Autres produits Kube
Other Kube range products



P.102

P.102

P.123

P.151

P.151

P.196

P.40-41

P.40-41

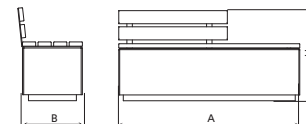

Ref.	A	B	H
UM372SLP	500 mm	500 mm	775 mm
UM372SLM	500 mm	500 mm	490mm
UM372LP	2000 mm	500 mm	775mm
UM372LM	2000 mm	500 mm	490mm

*Opcional | En Option | Optional



Trau

By BENITO © ©

Acero galvanizado con tratamiento Ferrus, proceso protector del hierro, que garantiza una óptima resistencia a la corrosión. Pies imprimación epoxi y pintura poliéster en polvo color negro forja y asiento imprimación epoxi y pintura poliéster en polvo color gris plata RAL 9006. Anclaje recomendado: Tornillos de fijación al suelo de M10 según superficie y proyecto.

Acier galvanisé avec le traitement Ferrus, processus protecteur de l'acier qui garantit une résistance optimale à la corrosion. Finition pieds avec primaire époxy + Thermolaquage polyester noir de forge et siège avec primaire époxy + Thermolaquage polyester RAL 9006. Scellement recommandé: Tiges de scellement filetées de M10 en fonction du sol et du projet.

Galvanized steel treated with Ferrus treatment, a protector process which guarantees a high resistance to the rust conforming to the spray salt fog test. Supports with epoxi primer coating and polyester black forge and seat with epoxi primer coating and polyester silver grey RAL 9006 powder coating finish. Recommended anchorage: M10 fixing bolts for anchoring to the ground, depending on the surface and the project.



TRAUKIT*

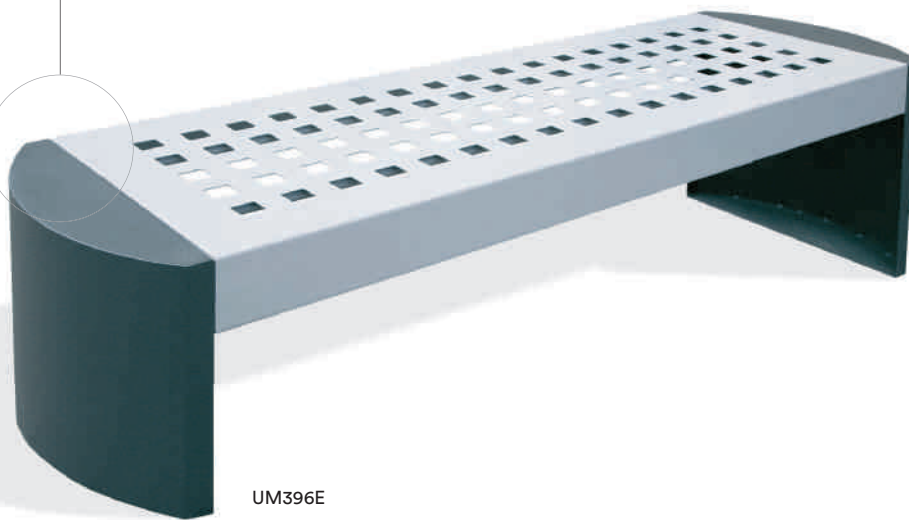

UM396E

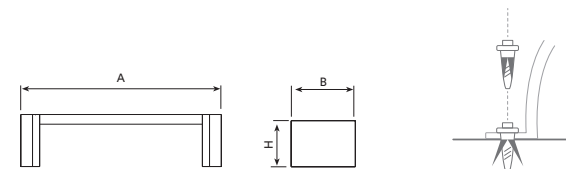

Ref.	A	B	H	H1
UM396E	2000 mm	630 mm	510 mm	-

*Opcional | En Option | Optional





Trau-H

Hormigón prefabricado color gris granítico de aspecto liso. Banco Kit de fácil ensamblaje insitu en la obra. Ahorro en los costes de transporte y almacenaje. Anclaje recomendado: Apoyado por su propio peso.

Béton préfabriqué hydrofuge couleur gris granite d'aspect lisse. Banc type Kit facile à assembler sur place. Coûts de transport et de stockage moindres. Ancrage recommandé : posé à terre

Pre-cast smooth granite grey concrete. Bench kit that is easy to assemble in situ at the work site, which saves storage and transport costs. Recommended anchoring: Free standing.

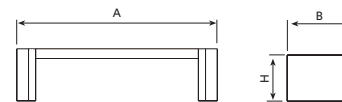
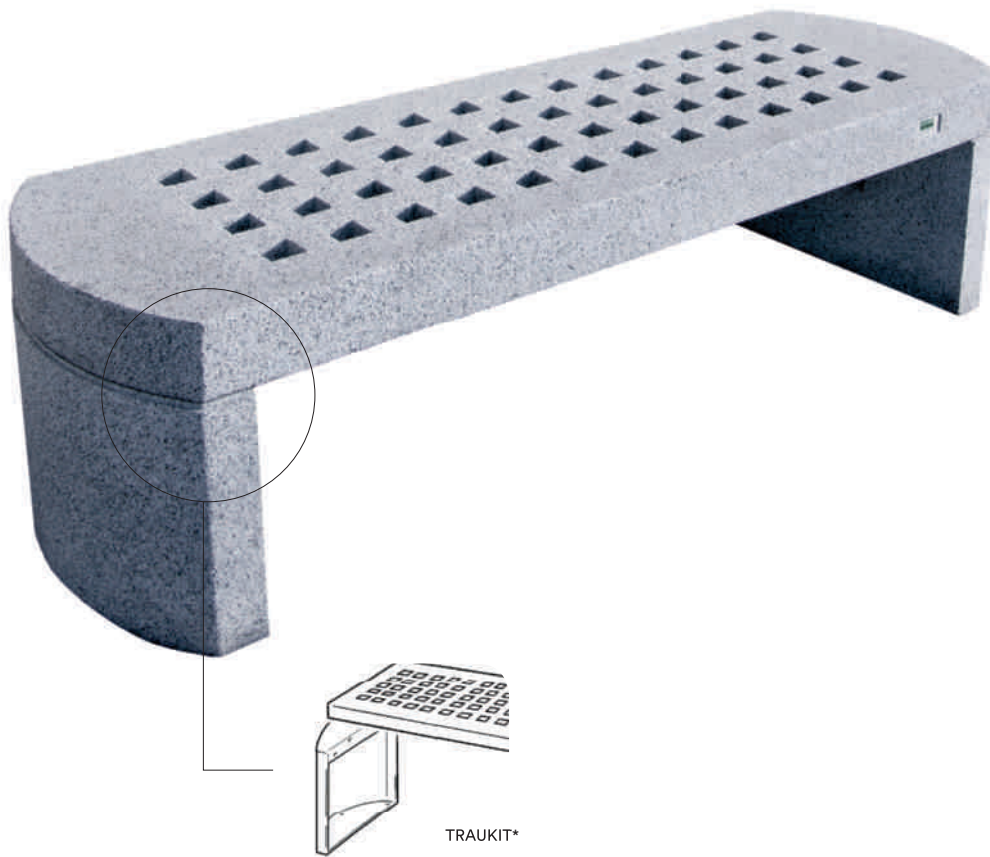

Ref.	A	B	H
UM396H	2000 mm	630 mm	510 mm

*Opcional | En Option | Optional

Volga

Hormigón prefabricado armado color gris granítico de aspecto liso o de hormigón prefabricado armado color blanco granítico. Se puede colocar en elementos aislados o en grupos. Anclaje recomendado: apoyado en el suelo en sus extremos robustos con el objetivo de facilitar la limpieza y el mantenimiento.

Béton préfabriqué gris granite, aspect lisse ou béton armé préfabriqué, couleur blanc granite. . Peut être placé séparément ou en groupes. Ancrage recommandé: posé à terre sur des extrémités résistantes, dans le but de faciliter le nettoyage et l'entretien.

Pre-cast smooth granite grey concrete or pre-cast reinforced polished granite white concrete. May be positioned individually or in groups. Recommended anchoring: supported on the ground by its strong ends, which allows for easy cleaning and maintenance.



UM369G



UM369

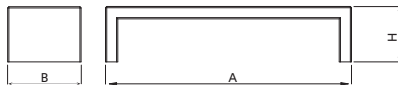

Ref.	A	B	H
UM369	2000 mm	600 mm	450 mm
UM369G	2000 mm	600 mm	450 mm



UM371L

Ela

By BENITO © ©

Asiento de hormigón armado hidrófugo moldeado, color blanco granítico pulido. Estructura de acero inoxidable mate. Anclaje recomendado: Apoyado por su propio peso. Opcional se puede combinar con listones de madera tropical de sección 110x35mm, tratada con Lignus, protector fungicida, insecticida e hidrófugo. Acabado color natural.

Assise en béton armé hydrofuge moulé couleur blanc granite poli. Structure en acier inoxydable mate. Anclage recommandé : posé à terre. En option : possibilité de combiner avec des lattes en bois tropical de section 110 x 35 mm, traité avec Lignus, protecteur fongicide, insecticide et hydrofuge. Finition teinte naturelle.

Pre-cast reinforced waterproof polished granite white concrete seat. Matte stainless steel structure. Recommended anchoring: free-standing. Optional: This product can be combined with 110 x 35 mm tropical wood slats, which have been treated with Lignus, a fungicide, insecticide and waterproofing agent. Natural colour finish.



UM371LM



UM371LP

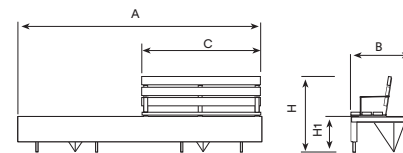

Ref.	A	B	C	H	H1
UM371L	3000 mm	800 mm	-	420 mm	-
UM371LP	3000 mm	800 mm	1800 mm	870 mm	420 mm
UM371LM	3000 mm	800 mm	-	460 mm	420 mm

Ela mini

By BENITO © ©

Asiento de hormigón armado hidrófugo moldeado, color blanco granítico pulido. Estructura de acero inoxidable mate. Anclaje recomendado: Apoyado por su propio peso. Opcional se puede combinar con listones de madera tropical de sección 110x35mm, tratada con Lignus, protector fungicida, insecticida e hidrófugo. Acabado color natural.

Assise en béton armé hydrofuge moulé couleur blanc granite poli. Structure en acier inoxydable mate. Anclage recommandé : posé à terre. En option : possibilité de combiner avec des lattes en bois tropical de section 110 x 35 mm, traité avec Lignus, protecteur fongicide, insecticide et hydrofuge. Finition teinte naturelle.

Pre-cast reinforced waterproof polished granite white concrete seat. Matte stainless steel structure. Recommended anchoring: free-standing. Optional: This product can be combined with 110 x 35 mm tropical wood slats, which have been treated with Lignus, a fungicide, insecticide and waterproofing agent. Natural colour finish.



UM371L2

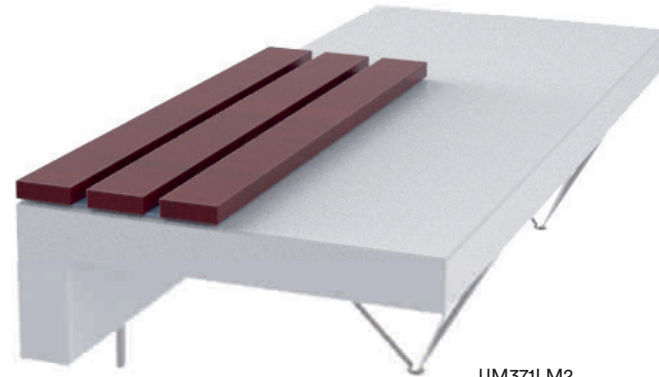

UM371LM2

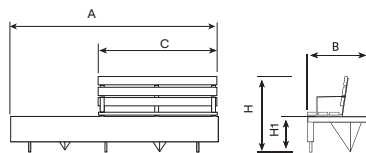

Ref.	A	B	C	H	H1
UM371L2	2000 mm	800 mm	-	420 mm	-
UM371LP2	2000 mm	800 mm	1200 mm	870 mm	420 mm
UM371LM2	2000 mm	800 mm	-	460 mm	420 mm

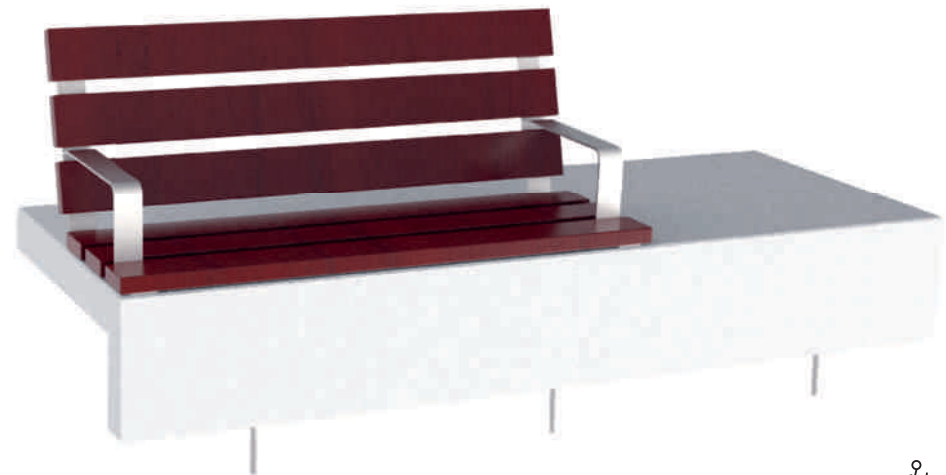

UM371LP2



Toledo

Hormigón prefabricado armado color blanco granítico. Anclaje: Apoyado en el suelo en sus extremos robustos con el objetivo de facilitar la limpieza y el mantenimiento. Opcional: Se puede fabricar con respaldo sujetado por cuatro varillas de acero revestidas de tubo de acero inoxidable.

Béton armé préfabriqué, couleur blanc granite. Ancre : posé à terre sur des extrémités résistantes, dans le but de faciliter le nettoyage et l'entretien. En option : dossier fixé sur 4 tiges avec revêtement en tube d'acier inoxydable.

Pre-cast reinforced polished granite white concrete. Anchoring: Supported on the ground by its strong ends, which allows for easy cleaning and maintenance. Optional: can be manufactured with a backrest fastened by four steel bars covered by stainless steel tube.



UM370



UM370R

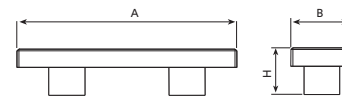

Ref.	A	B	H	H1
UM370	2000 mm	450 mm	425 mm	-
UM370R	2000 mm	560 mm	845 mm	450 mm

*Opcional | En Option | Optional



Alea

By BENITO © ©



UM395 



Pies y respaldo de acero galvanizado con tratamiento Ferrus, proceso protector del hierro, que garantiza una óptima resistencia a la corrosión. Imprimación epoxi y pintura poliéster en polvo color rojo cobre. Asiento formado por tres tablones de madera tropical de sección 150 × 45mm tratada con Lignus, protector fungicida, insecticida e hidrófugo. Acabado color natural. Tornillos de acero inoxidable. Anclaje recomendado: Tornillos de fijación al suelo de M10 según superficie y proyecto.

Piètement et dossier en acier galvanisé avec traitement Ferrus, procédé qui protège l'acier et garantit une résistance optimale à la corrosion. Couche primaire époxy et thermolaquage polyester, couleur rouge cuivre. Siège constitué de trois lattes de section 150 × 45 mm, en bois tropical traité Lignus, protecteur fongicide, insecticide et hydrofuge. Finition teinte naturelle. Vis en acier inoxydable. Ancrage recommandé : vis M10 pour la fixation au sol, en fonction de la surface et du projet.

Galvanised steel legs and backrest treated with Ferrus, a protective process for iron that guarantees high corrosion resistance. Epoxy primer coating and copper red polyester powder coated finish. Three tropical wood boards measuring 150 × 45 mm, treated with Lignus, a fungicide, insecticide and waterproofing agent. Natural colour finish. Stainless steel bolts. Recommended anchoring: M10 bolts to anchor to the ground, depending on the surface and the project.



UM395B

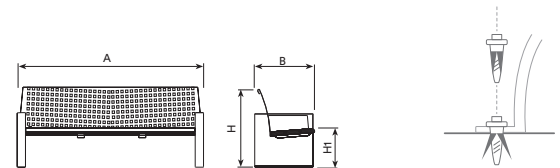

Ref.	A	B	H	H1	
UM395	2095 mm	670 mm	880 mm	425 mm	✓
UM395B	2100 mm	675 mm	590 mm	430 mm	

*Opcional | En Option | Optional

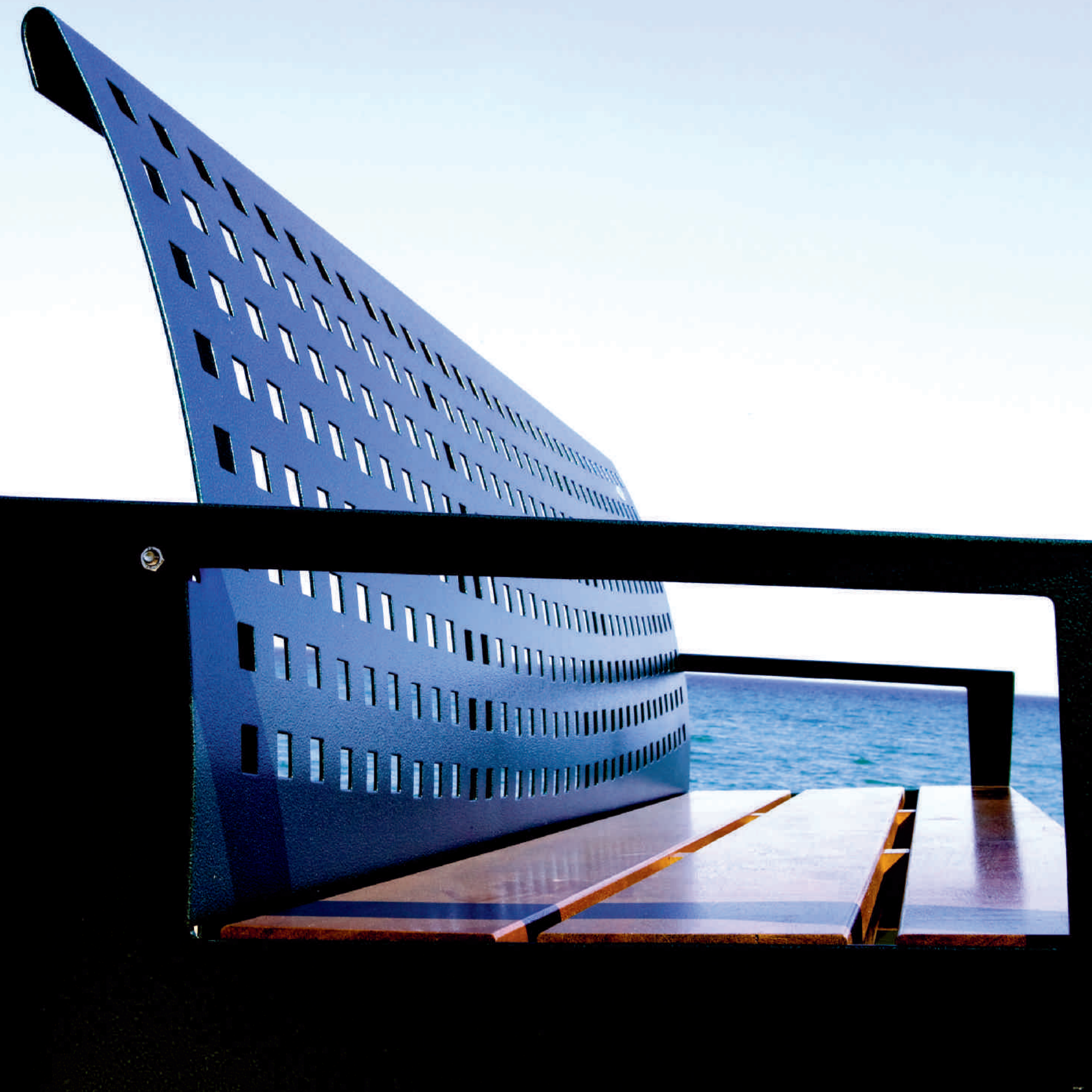

City

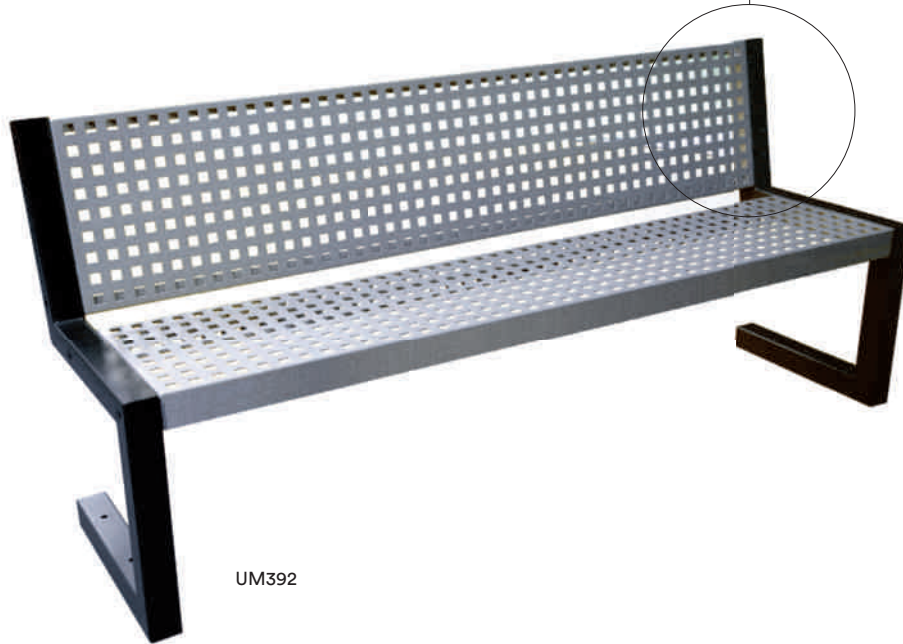

UM392

Acero galvanizado con tratamiento Ferrus, proceso protector del hierro, que garantiza una óptima resistencia a la corrosión. Pies con imprimación epoxi y pintura poliéster en polvo color negro forja y asiento con imprimación epoxi y pintura poliéster en polvo color gris plata RAL 9006. Anclaje recomendado: Tornillos de fijación al suelo de M10 según superficie y proyecto.

Acier galvanisé avec traitement Ferrus, procédé qui protège l'acier et garantit une résistance optimale à la corrosion. Piètement avec couche primaire époxy et thermolaquage polyester noir de forge. Siège avec couche primaire époxy et thermolaquage polyester, couleur gris RAL 9006. Ancrage recommandé : vis M10 pour la fixation au sol, en fonction de la surface et du projet.

Galvanised steel treated with Ferrus, a protective process that guarantees high corrosion resistance. Legs with epoxy primer coating and black wrought iron coloured polyester powder coated finish, and seat with epoxy primer coating and silver grey RAL 9006 polyester powder coated finish. Recommended anchoring: M10 bolts to anchor to the ground, depending on the surface and the project.

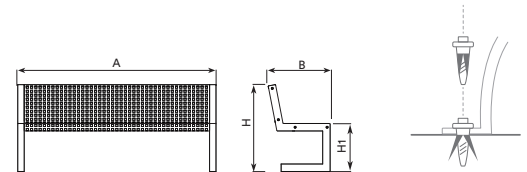

Ref.	A	B	H	H1
UM392	1860 mm	580 mm	815 mm	450 mm

*Opcional | En Option | Optional



Essen

By BENITO © ©



Acero galvanizado con tratamiento Ferrus, proceso protector del hierro, que garantiza una óptima resistencia a la corrosión. Acabado imprimación epoxi y pintura poliéster en polvo color negro forja. Anclaje recomendado: Tornillos de fijación al suelo de M10 según superficie y proyecto. Opcional: Con apoyabrazos (UM379MA).

Acier galvanisé avec traitement Ferrus, procédé qui protège l'acier et garantit une résistance optimale à la corrosion. Finition couche primaire époxy et thermolaquage polyester noir de forge. Ancrage recommandé : vis M10 pour la fixation au sol, en fonction de la surface et du projet. En option : avec accoudoirs (UM379MA).

Galvanised steel treated with Ferrus, a protective process for iron that guarantees high corrosion resistance. Epoxy primer coating and black wrought iron coloured polyester powder coated finish. Recommended anchoring: M10 bolts to anchor to the ground, depending on the surface and the project. Optional: With arm rest (UM379MA).

UM379M



ESSENKIT*

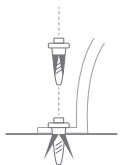
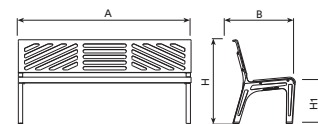

Ref.	A	B	H	H1	
UM379M	1660 mm	620 mm	805 mm	445 mm	✓

*Opcional | En Option | Optional



Valles



UM340D



UM340B

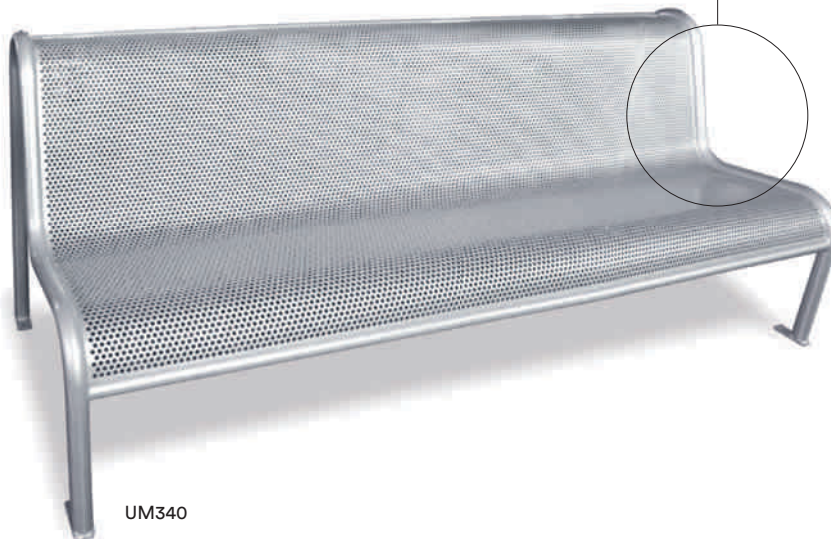

UM340

Pies de tubo de acero de Ø40 mm con asiento y respaldo de plancha de acero perforada de 2 mm de grueso y agujeros de Ø7 mm. Acabado zincado electrolítico por inmersión y pintura poliéster en polvo color gris Ral-9006. Anclaje recomendado: Tornillos de fijación al suelo de M10 según superficie y proyecto.

Piètement tubulaire de Ø 40 mm avec assise et dossier en tôle d'acier perforé de 2 mm d'épaisseur et trous de Ø 7 mm. Finition zingage électrolytique par immersion et thermolaquage polyester gris RAL 9006. Ancrage recommandé : vis M10 pour la fixation au sol, en fonction de la surface et du projet.

Legs made of Ø40 mm tube. Seat and backrest made of 2 mm-thick steel sheet perforated with Ø7 mm holes. Electro-galvanised by immersion and grey RAL 9006 polyester powder coated finish. Recommended anchoring: M10 bolts to anchor to the ground, depending on the surface and the project.



Con apoyabrazos*
Avec accoudoirs*
With armrest*



UM340AP

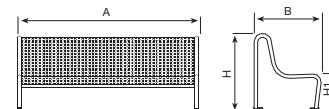

Ref.	A	B	H	H1
UM340	2080 mm	760 mm	855 mm	430 mm
UM340D	2080 mm	1500 mm	850 mm	430 mm
UM340B	2080 mm	500 mm	470 mm	450 mm

*Opcional | En Option | Optional



Fundicion



Pies, respaldo y asiento de fundición dúctil con imprimación epoxi y pintura poliuretano acrílico color negro forja. Anclaje recomendado: Tornillos de fijación al suelo de M10 según superficie y proyecto.

Piètement, dossier et siège en fonte ductile avec une couche primaire époxy et une peinture polyuréthane acrylique de couleur noir de forge. Ancrage recommandé : vis M10 pour la fixation au sol, en fonction de la surface et du projet.

Legs, backrest and seat made of ductile iron with epoxy primer coating and black wrought iron coloured polyurethane acrylic paint finish. Recommended anchoring: M10 bolts to anchor to the ground, depending on the surface and the project.

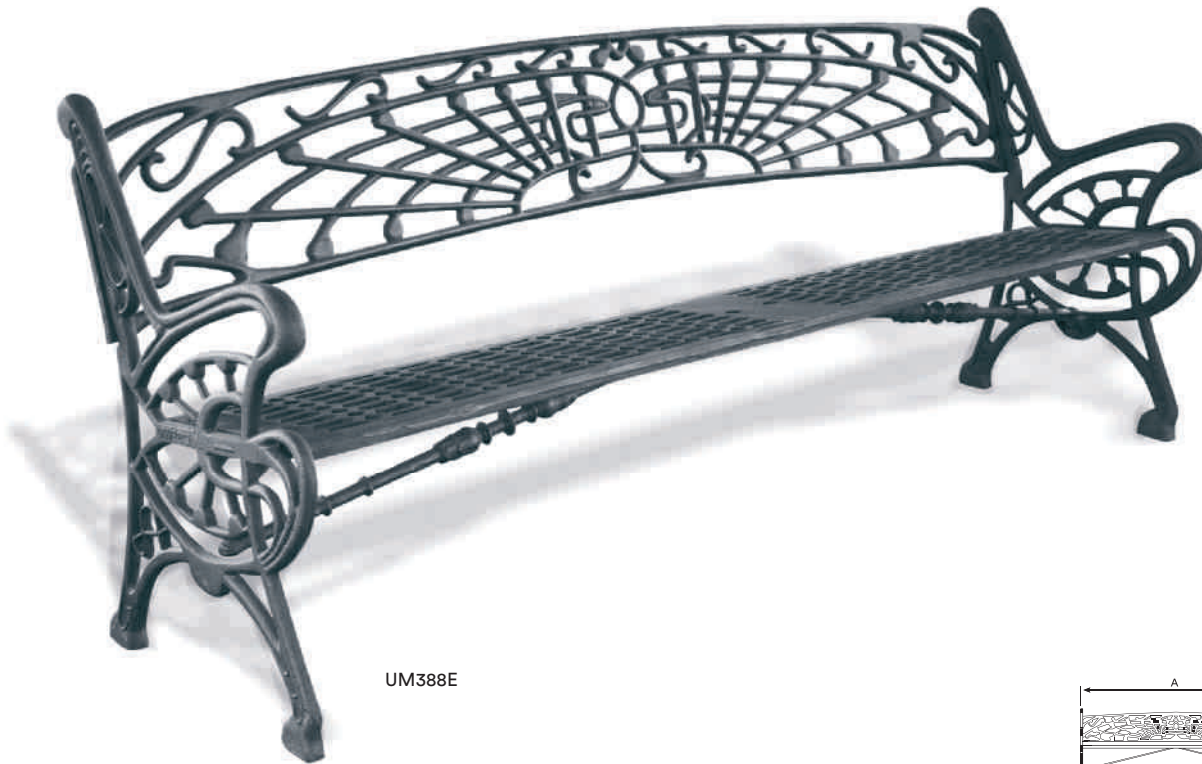

UM388E

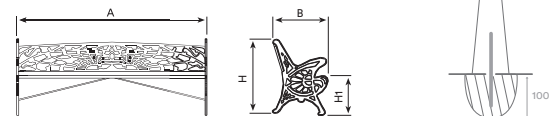

Ref.	A	B	H	H1	
UM388E	2060 mm	730 mm	850 mm	430 mm	✓

*Opcional | En Option | Optional



Goteborg



Madera para exterior tratada autoclave vac-vac incoloro riesgo III con protector orgánico, dotando a la madera de una gran estabilidad al movimiento y resistencia a la humedad. Tratada con Lignus, protector fungicida, insecticida e hidrófugo. Acabado color natural. Anclaje recomendado: Tornillos de fijación al suelo de M10 según superficie y proyecto.

Bois tropical pour extérieur traité autoclave vac-vac, incolore risque III avec protecteur organique, conférant au bois une grande stabilité et une résistance à l'humidité, traité avec Lignus, protecteur fongicide, insecticide et hydrofuge. Finition teinte naturelle. Ancrage recommandé : vis M10 pour la fixation au sol, en fonction de la surface et du projet.

Made of tropical wood for outdoor use that has been treated with colourless vac-vac autoclave class III, an organic protector that guarantees stability of movement and provides resistance to humidity. Additionally, it has also been treated with Lignus, a fungicide, insecticide and waterproofing agent. Natural colour finish. Recommended anchoring: M10 bolts to anchor to the ground, depending on the surface and the project.



UM345

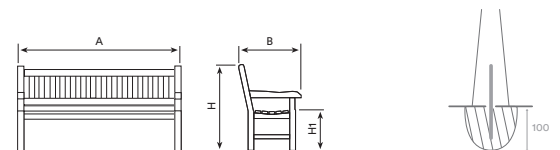

Ref.	A	B	H	H1
UM345	1650 mm	650 mm	915 mm	425 mm

*Opcional | En Option | Optional





- * Acabado imprimación epoxi y pintura poliéster en polvo color MARSON.
- * Finition couche primaire époxy et thermo-laquage polyester teinte MARSON.
- * Epoxy primer coating and MARSON polyester powder coated finish.



UM314T



UM314



UM314B



UM314G

Otros productos Olea
Autres produits Olea
Other Olea range products



P.108-109

P.108-109

P.118

P.142

P.142

P.191

Olea

By BNT Team BENITO

Pies tubulares de acero corten de 50 × 100 mm. Tablones de sección 210 × 50 mm en madera de pino tratada en autoclave vacío-presión clase 4 contra la carcoma, termitas e insectos. Tornillería de acero inoxidable. Anclaje recomendado: Tornillos de fijación al suelo de M10 según superficie y proyecto.

_ Sabias que... la madera natural "respira" és decir, absorbe y desprende la humedad en ambiente seco. Por lo tanto, es normal que puedan aparecer grietas en la madera. No influencia para nada en su capacidad de resistencia y su durabilidad.

_ La oxidación del acero corten evoluciona con el paso del tiempo y se oxida, más o menos rapido, en función de la temperatura ambiente y la humedad.

Piètement en tôle d'acier Corten de 50 × 100 mm. Lattes de section 210 × 50 mm en bois de pin traité en autoclave sous vide d'air (classe 4 contre les vers à bois, les termites et les insectes). Vis en acier inoxydable. Ancrage recommandé: vis M10 pour la fixation au sol, en fonction de la surface et du projet.

_ Saviez vous que... le bois naturel "respire", c'est-à-dire, qu'il absorbe et restitue de l'humidité dans une atmosphère sèche. Il est par conséquent normal que des fissures apparaissent dans le bois. Ceci n'influence en rien sa capacité de résistance et sa durabilité.

_ L'oxydation de l'acier évoluera au fil du temps, et sera plus ou moins rapide en fonction de la température ambiante et de l'humidité.

Legs in 50 × 100 mm untreated corten steel. 210 × 50 mm pine wood boards, vacuum-pressure treated in autoclave (class 4) against woodworm, termites and insects. Stainless steel bolts. Recommended anchoring: M10 bolts to anchor to the ground, depending on the surface and the project.

_ Did you know... natural wood "breathes" i.e. it absorbs humidity and releases it in dry atmospheres. It is therefore normal for cracks to appear in wood. This has no effect whatsoever on its strength and durability.

_ The rustiness from Corten steel evolves overtime, which means that this material sooner or later will get rusty depending on the humidity and temperature levels.

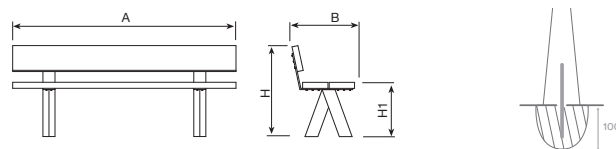

Ref.	A	B	H	H1
UM314	1850 mm	518 mm	754 mm	450 mm
UM314T	500 mm	430 mm	-	650 mm
UM314B	1850 mm	430 mm	-	450 mm
UM314G	1850 mm	490 mm	910 mm	660 mm

*Opcional | En Option | Optional





UM311RS



UM311S



UM311



UM311R



UM311RD

Otros productos Gavarres
Autres produits Gavarres
Other Gavarres range products



P:96-97



P:190

Gavarres

By Martí Franch © BENITO

Pies en plancha de acero corten de 8 mm. Tablones de sección 210 x 58 mm en madera de pino tratada en autoclave vacío-presión clase 4 contra la carcoma, termitas e insectos. Tornillería de acero inoxidable. Anclaje recomendado: Mediante pernos.

Sabias que... la madera natural "respira" és decir, absorbe y desprende la humedad en ambiente seco. Por lo tanto, és normal que puedan aparecer grietas en la madera. No influencia para nada en su capacidad de resistencia y su durabilidad. P. 10

Piètement en tôle d'acier Corten de 8 mm. Lattes de section 210 x 58 mm en bois de pin traité en autoclave sous vide d'air (classe 4 contre les vers à bois, les termites et les insectes). Vis en acier inoxydable. Ancrage recommandé: par boulonnage.

Saviez vous que... le bois naturel "respire", c'est-à-dire, qu'il absorbe et restitue de l'humidité dans une atmosphère sèche. Il est par conséquent normal que des fissures apparaissent dans le bois. Ceci n'influence en rien sa capacité de résistance et sa durabilité. P. 10

Legs in 8 mm untreated steel sheet. 210 x 58 mm pine wood boards, vacuum-pressure treated in autoclave (class 4) against woodworm, termites and insects. Stainless steel bolts. Recommended anchoring: With bolts.

Did you know... natural wood "breathes" i.e. it absorbs humidity and releases it in dry atmospheres. It is therefore normal for cracks to appear in wood. This has no effect whatsoever on its strength and durability. P. 10

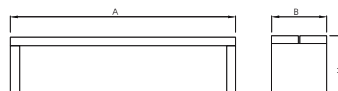

Ref.	A	B	H	H1
UM311R	1850 mm	575 mm	810 mm	500 mm
UM311RS	460 mm	440 mm	800 mm	440 mm
UM311S	460 mm	440 mm	440 mm	440 mm
UM311RD	3680 mm	440 mm	800 mm	440 mm
UM311	1840 mm	440 mm	440 mm	440 mm

*Opcional | En Option | Optional



Nordico

Madera de pino con tratamiento autoclave a vacío-presión clase 4 contra la carcoma, termitas e insectos. Anclaje recomendado: Tornillos de fijación al suelo de M10 según superficie y proyecto.

Sabías que... la madera natural “respira” és decir, absorbe y desprende la humedad en ambiente seco. Por lo tanto, és normal que puedan aparecer grietas en la madera. No influencia para nada en su capacidad de resistencia y su durabilidad. P. 10

Bois de pin traité en autoclave sous vide d'air (classe 4 contre les vers à bois, les termites et les insectes). Anclage recommandé : vis M10 pour la fixation au sol, en fonction de la surface et du projet.

Saviez vous que... le bois naturel “respire”, c'est-à-dire, qu'il absorbe et restitue de l'humidité dans une atmosphère sèche. Il est par conséquent normal que des fissures apparaissent dans le bois. Ceci n'influence en rien sa capacité de résistance et sa durabilité. P. 10

Made of pine wood vacuum-pressure treated in an autoclave against woodworm, termites and insects (Class 4). Recommended anchoring: M10 bolts to anchor to the ground, depending on the surface and the project.

Did you know... natural wood “breathes” i.e. it absorbs humidity and releases it in dry atmospheres. It is therefore normal for cracks to appear in wood. This has no effect whatsoever on its strength and durability. P. 10



UM350

Otros productos en madera de pino
Autres produits en pin
Other products made of pinewood



P.152-153



P.124-125



P.99



P.192



P.180-181



P.180-181



P.180-181

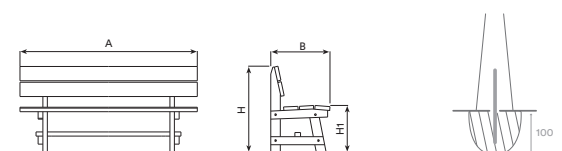

Ref.	A	B	H	H1
UM350	1750 mm	560 mm	855 mm	455 mm

*Opcional | En Option | Optional





UM304NMTP



UM304NSMTP



UM374MTP

Equs technical wood

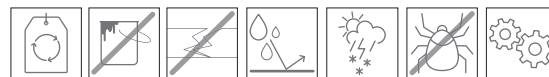

Pies de fundición dúctil. Perfiles de la mezcla de madera reciclada y polímeros reciclados de sección 110×35mm.

- Ecológico, proviene de producto reciclado y a la vez es reciclable.
- No requiere mantenimiento.
- No se astilla ni se agrieta, tampoco se pudre ni se reseca
- Resistente a la humedad.
- Alta resistencia a las inclemencias.
- Anti insectos, carcoma, termitas.
- Resistente y duradero

Piètment en fonte ductile. Profils en bois recyclé et polymère de section 110×35mm.

- Ecologique, provient de matière recyclée et est également recyclable.
- Libre d'entretien.
- No se fend pas, ne se fissure pas, ne pourrit pas et ne se dessèche pas.
- Résistant à l'humidité.
- Haute résistance aux intempéries.
- Anti insectes, ver à bois, thérmites.
- Résistant et durable.

Supports made of ductile iron. It consists of 110×35mm slats with a mixture of wood and polymers both recycled.

- Environmentally friendly, it comes from recycled material and is recyclable too.
- No maintenance required.
- No cracks, no splinters, no rot and no drying.
- Moisture-resistant.
- High resistance to hard weather conditions.
- Long-lasting and strong.

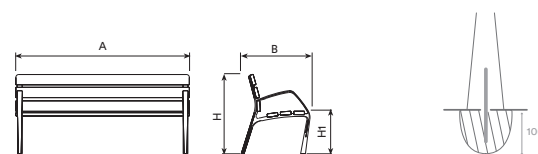

Ref.	A	B	H	H1
UM304NMTP	1800 mm	710 mm	825 mm	450 mm
UM304NSMTP	700 mm	710 mm	825 mm	450 mm
UM374MTP	1800 mm	630 mm	770 mm	445 mm

*Opcional | En Option | Optional



Ecosens

By BNT Team BENITO



Pies de acero de 50x8 mm con tratamiento Ferrus. Perfiles de polímeros reciclados de sección 110x40x1800mm. Ecológico, proviene de producto reciclado y a la vez es reciclable. No requiere mantenimiento. No se astilla ni se agrieta, tampoco se pudre ni se reseca. Resistente a la humedad. Alta resistencia a las inclemencias. Resistente y duradero.

Piètment en acier de 50x8 mm avec traitement Ferrus. Profils en polymère de section 110x40x1800mm. Ecologique, provient de matière recyclée et est également recyclable. Libre d'entretien. No se fend pas, ne se fissure pas, ne pourrit pas et ne se dessèche pas. Résistant à l'humidité. Haute résistance aux intempéries. Résistant et durable.

Supports made of steel with Ferrus treatment. Made of 110x40x1800mm recycled polymers slats. Environmentally friendly, it comes from recycled material and is recyclable too. No maintenance required. No cracks, no splinters, no rot and no drying. Moisture-resistant. High resistance to hard weather conditions. Long-lasting and strong.



plástico reciclado reBnew
plastique recyclé reBnew
recycled plastic reBnew

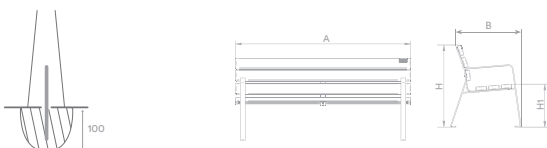

Ref.	A	B	H
UM362K-C	1800 mm	440 mm	840 mm

*Optional | En Option | Optional

Otros productos Ecosens
Autres produits Ecosens
Other Ecosens range products



P.86

P.86

reBnew

Productos 100% plástico reciclado Rebnew
Produits 100% plastique recyclé Rebnew
Products 100% recycled plastic Rebnew



PLÁSTICO RECICLADO REBNEW UN MATERIAL EXCEPCIONAL

- Resistencia a la intemperie
- Resistente a aceites, ácidos y agua de mar
- No se degrada
- No se astilla
- Antigraffiti
- Resistente a la humedad, no absorbe agua, de secado rápido
- ECOLÓGICO proviene de producto reciclado y a la vez es reciclable
- Larga vida útil
- 100% Reciclable
- Sin contaminantes
- Fabricado de plásticos reciclados de alta calidad

PREMIADO CON “DER BLAUE ENGEL”

Producto con baja incidencia ambiental durante su ciclo de vida.

PLASTIQUE RECYCLÉ REBNEW UN MATÉRIEL EXCEPTIONNEL

- Résistant aux intempéries
- Résistant aux huiles, acides et eau de mer
- Ne se dégrade pas
- Anti-graffiti
- Résistant aux humidité, n'absorbe pas l'eau, sèche rapidement
- ECOLOGIQUE, provient de matière recyclée et est également recyclable
- Longue vie utile
- 100% Recyclable
- Sans contaminants
- Fabriqué à partir de plastiques recyclés de haute qualité

PRIX “DER BLAUE ENGEL”.

Produit à faible impact environnemental durant son cycle de vie.

REBNEW RECYCLED PLASTIC AN EXCEPTIONAL MATERIAL

- Weather resistant
- Oil, acid & seawater resistant
- It does not degrade
- It doesn't splinter
- Anti-graffiti
- High resistance to hard weather conditions, no water absorption & fast drying
- ENVIRONMENTALLY FRIENDLY, it comes from recycled material and is recyclable too.
- Long lifespan
- 100% Recyclable
- No pollutants
- Made of high quality recycled plastic

Awarded “DER BLAUE ENGEL”

Product with low environmental impact during its life cycle.





SIS
UM337



SIS B
UM337B



RAR
UM338B



TRO
UM336

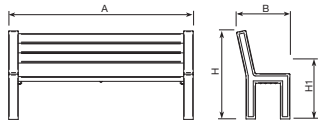
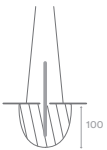

Ref.	A	B	H	H1
UM337	1930 mm	560 mm	925 mm	474 mm
UM337B	1930 mm	460 mm	450 mm	-
UM336	2000 mm	670 mm	820 mm	440 mm
UM338B	1800 mm	710 mm	475 mm	-

Otros productos ReBnew
Autres produits ReBnew
Other ReBnew range products



P.87



P.119



P.119



P.150



P.192



P.193

Acero | Acier | Steel

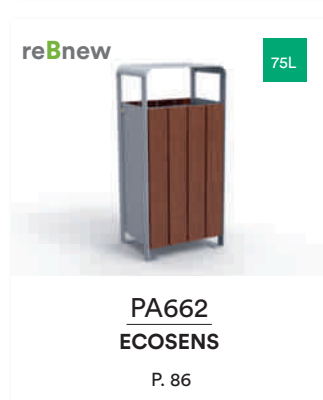

Madera | Bois | Wood

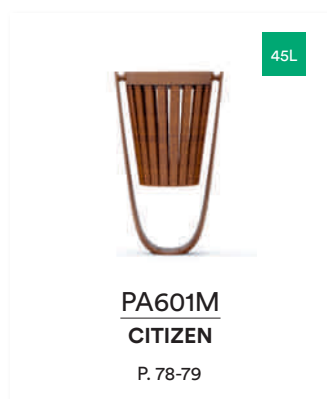

Hormigón | Béton préfabriqué | Concrete

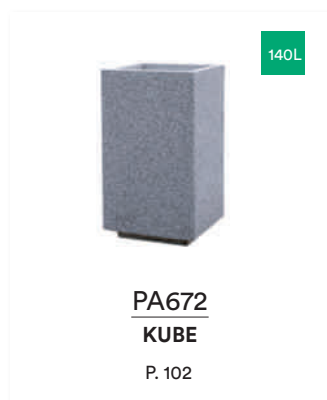

Acero corten | Acier corten | Corten steel



Selectiva | Sélectif | Selective





PA601

Estructura y cubeta de acero con tratamiento Ferrus, proceso protector del hierro, que garantiza una óptima resistencia a la corrosión. Imprimación epoxi y pintura poliéster en polvo. Aro de acero zincado para fijar la bolsa. Anclaje recomendado: Mediante pernos de expansión.

Structure et receptacle en acier avec traitement Ferrus, procédé qui protège le fer et garantit une résistance optimale à la corrosion. Couche primaire époxy et thermolaquage polyester. Anneau en acier zingué pour fixer le sac plastique. Ancrage recommandé : Par boulons à expansion.

Steel structure treated with Ferrus, a protective process for iron that guarantees high corrosion resistance. Ring to hold the bag made of galvanised steel. Recommended anchoring: expansion bolts.



PA601V

Acero con tratamiento Ferrus, proceso protector del hierro, que garantiza una óptima resistencia a la corrosión. Imprimación epoxi y pintura poliéster en polvo. Aro de acero zincado para fijar la bolsa. Anclaje recomendado: Mediante pernos de expansión.

Acier avec traitement Ferrus, procédé qui protège le fer et garantit une résistance optimale à la corrosion. Couche primaire époxy et thermolaquage polyester. Anneau en acier zingué pour fixer le sac plastique en acier zingué. Ancrage recommandé : Par boulons à expansion.

Steel treated with Ferrus, a protective process for iron that guarantees high corrosion resistance. Ring to hold the bag made of galvanised steel. Recommended anchoring: expansion bolts.

Citizen

By Eugeni Quitllet © © BENITO

Otros productos Citizen
Autres produits Citizen
Other Citizen range products

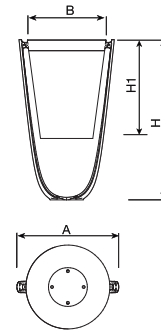

P:16-17



P:16-17



P:16-17



PA601M



Estructura de acero con tratamiento Ferrus, proceso protector del hierro, que garantiza una óptima resistencia a la corrosión. Imprimación epoxi y pintura poliéster en polvo. Listones de madera para exterior tratada con Lignus, protector fungicida, insecticida e hidrófugo. Aro de acero zincado para fijar la bolsa. Anclaje recomendado: Mediante pernos de expansión.

Structure en acier avec traitement Ferrus, procédé qui protège le fer et garantit une résistance optimale à la corrosion. Couche primaire époxy et thermolaquage polyester. Extérieure avec en bois, traité avec Lignus, protecteur fongicide, insecticide et hydrofuge. Anneau en acier zingué pour fixer le sac plastique. Ancrage recommandé : par boulons à expansion.

Steel treated with Ferrus, a protective process for iron that guarantees high corrosion resistance. Wood slats for outdoor use treated with Lignus, a fungicide, insecticide and waterproofing agent. Ring to hold the bag made of galvanised steel. Recommended anchoring: Expansion bolts.

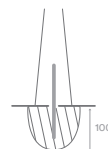

Ref.		A	B	H	H1
PA601	60L	546 mm	450 mm	918 mm	566 mm
PA601V		546 mm	450 mm	918 mm	62 mm
PA601M	45L	546 mm	450 mm	918 mm	568 mm



PA692SGRH

Fácil vaciado
Facile vidage
Easy emptying



Argo plus

By BENITO © ©



Cubeta de acero galvanizada reforzada con ventanillas realizadas con láser, con tratamiento Ferrus, proceso protector del hierro que garantiza una óptima resistencia a la corrosión. Imprimación epoxi y pintura poliéster en polvo color gris RAL9006. Cubeta apoyada en una estructura maciza y base de anclaje triangular con agujeros para su fijación al suelo. Anclaje recomendado: Mediante tres pernos de expansión M8.

Corbeille en acier galvanisé renforcée avec des trous carrés réalisés au laser, avec traitement Ferrus, procédé qui protège l'acier et garantit une résistance optimale à la corrosion. Couche primaire époxy et thermolaquage polyester grise RAL9006. Repose sur une structure massive et une base d'ancrage triangulaire avec des trous pour la fixation au sol. Ancrage recommandé : par trois boulons à expansion M8.

Reinforced galvanised steel bin with laser-cut holes treated with Ferrus, a protective process for iron that guarantees high corrosion resistance. Epoxy primer coating and grey RAL 9006 polyester powder coated finish. Bin is supported by means of a solid structure and a triangular anchoring base with holes to fix it to the ground. Recommended anchoring: Three M8 expansion bolts.

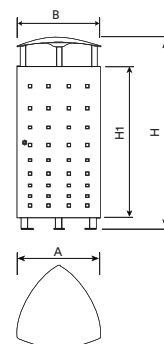

Ref.		A	B	H	H1	
PA692SGRH	70L.	400 mm	400 mm	1024 mm	785 mm	✓





PA693GR



Fácil vaciado
Facile vidage
Easy emptying



Argo

By BENITO © ©



Cubeta de acero galvanizada reforzada con ventanillas realizadas con láser, con tratamiento Ferrus, proceso protector del hierro que garantiza una óptima resistencia a la corrosión. Imprimación epoxi y pintura poliéster en polvo color gris RAL9006. Cubeta apoyada en una estructura maciza y base de anclaje triangular con agujeros para su fijación al suelo. Anclaje recomendado: Mediante tres pernos de expansión M8.

Corbeille en acier galvanisé renforcée avec des trous carrés réalisés au laser, avec traitement Ferrus, procédé qui protège l'acier et garantit une résistance optimale à la corrosion. Couche primaire époxy et thermolaquage polyester grise RAL9006. Repose sur une structure massive et une base d'ancrage triangulaire avec des trous pour la fixation au sol. Ancrage recommandé : par trois boulons à expansion M8.

Reinforced galvanised steel bin with laser-cut holes treated with Ferrus, a protective process for iron that guarantees high corrosion resistance. Epoxy primer coating and grey RAL 9006 polyester powder coated finish. Bin is supported by means of a solid structure and a triangular anchoring base with holes to fix it to the ground. Recommended anchoring: Three M8 expansion bolts.

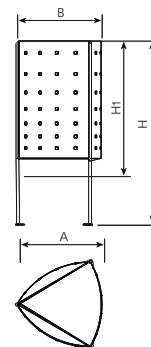

Ref.		A	B	H	H1
PA693GR	45L.	385 mm	385 mm	825 mm	485 mm



Dara

By BENITO © ©



Fabricada en acero galvanizado con tratamiento Ferrus, proceso protector que garantiza una óptima resistencia a la corrosión. Imprimación epoxi y pintura poliéster en polvo color negro forja. Cuerpo con sombrero y cenicero incorporado. Anclaje recomendado: Mediante cuatro pernos de expansión M8.

Fabriquée en acier galvanisé avec traitement Ferrus, procédé qui protège l'acier et garantit une résistance optimale à la corrosion. Couche primaire époxy et thermolaquage polyester noir de forge. Corps avec protège-pluie et cendrier incorporé. Ancrage recommandé : par quatre boulons à expansion M8.

Made from galvanised steel treated with Ferrus, a protective process that guarantees high corrosion resistance. Epoxy primer coating and black wrought iron coloured polyester powder coated finish. Body with built in lid and ashtray. Recommended anchoring: Four M8 expansion bolts.



PA694SMO

Fácil vaciado
Facile vidage
Easy emptying

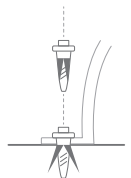
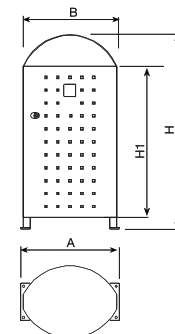
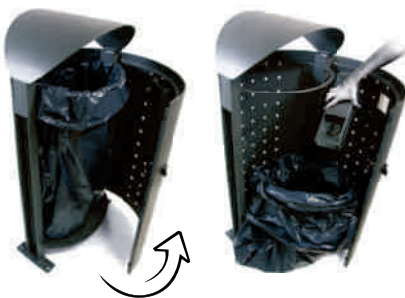

Ref.		A	B	H	H1	
PA694SMO	95L.	535 mm	370 mm	1000 mm	780 mm	





PA662



35L.



35L.

plástico reciclado reBnew
 plastique recyclé reBnew
 recycled plastic reBnew

PA662S2



Otros productos Ecosens
 Autres produits Ecosens
 Other Ecosens range products



P.73

Ecosens

By BNT Team BENITO



Pies de acero de 50×8 mm con tratamiento Ferrus. Perfiles de polímeros reciclados de sección 110×40×1800mm. Ecológico, proviene de producto reciclado y a la vez es reciclable. No requiere mantenimiento. No se astilla ni se agrieta, tampoco se pudre ni se reseca. Resistente a la humedad. Alta resistencia a las inclemencias. Resistente y duradero.

Piètment en acier de 50×8 mm avec traitement Ferrus. Profils en polymère de section 110×40×1800mm. Ecologique, provient de matière recyclée et est également recyclable. Libre d'entretien. No se fend pas, ne se fissure pas, ne pourrit pas et ne se dessèche pas. Résistant à l'humidité. Haute résistance aux intempéries. Résistant et durable.

Supports made of steel with Ferrus treatment. Made of 110×40×1800mm recycled polymers slats. Environmentally friendly, it comes from recycled material and is recyclable too. No maintenance required. No cracks, no splinters, no rot and no drying. Moisture-resistant. High resistance to hard weather conditions. Long-lasting and strong.

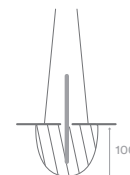
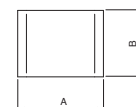
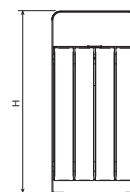

Ref.		A	B	H
PA662	75L	450 mm	350 mm	960 mm
PA662S2	35L + 35L	450 mm	350 mm	960 mm

Kom

Resistencia a la intemperie. Resistente a aceites, ácidos y agua de mar. No se degrada. No se astilla. Antigraffiti. Resistente a la humedad, no absorbe agua, de secado rápido. ECOLÓGICO proviene de producto reciclado y a la vez es reciclable. Larga vida útil. 100% Reciclable. Sin contaminantes. Fabricado de plásticos reciclados de alta calidad.

PREMIADO CON “DER BLAUE ENGEL” Producto con baja incidencia ambiental durante su ciclo de vida.

Résistant aux intempéries. Résistant aux huiles, acides et eau de mer. Ne se dégrade pas. Anti-graffiti. Résistant aux humidité, n'absorbe pas l'eau, sèche rapidement. ECOLOGIQUE, provient de matière recyclée et est également recyclable. Longue vie utile. 100% Recyclable. Sans contaminants. Fabriqué à partir de plastiques recyclés de haute qualité.

PRIX “DER BLAUE ENGEL”. Produit à faible impact environnemental durant son cycle de vie.

Weather resistant. Oil, acid & seawater resistant. It does not degrade. It doesn't splinter. Anti-graffiti. High resistance to hard weather conditions, no water absorption & fast drying. ENVIRONMENTALLY FRIENDLY, it comes from recycled material and is recyclable too. Long lifespan. 100% Recyclable. No pollutants. Made of high quality recycled plastic.

Awarded “DER BLAUE ENGEL” Product with low environmental impact during its life cycle.

reBnew

Productos 100% plástico reciclado Rebnew
Produits 100% plastique recyclé Rebnew
Products 100% recycled plastic Rebnew



PA630

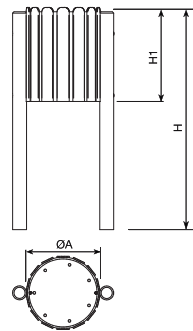

Ref.		Ø A	B	H	H1
PA630	60L	420 mm	-	1250 mm	515 mm



Otros productos ReBnew
Autres produits ReBnew
Other ReBnew range products



*VC4



PA606

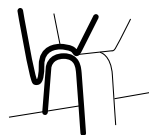

Bloqueo de seguridad
Buttor de securite
Security locking system

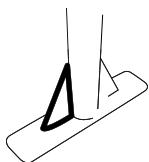

Pies reforzados
Pieds reforcés
Reinforced gusset plates



Fácil vaciado
Facile vidage
Easy emptying

Bcn

Acero con tratamiento Ferrus, proceso protector del hierro, que garantiza una óptima resistencia a la corrosión. Imprimación epoxi y pintura poliéster en polvo color negro forja. Anclaje recomendado: Mediante cuatro pernos de expansión de M8.

Acier avec traitement Ferrus, procédé qui protège le fer et garantit une résistance optimale à la corrosion. Couche primaire époxy et thermolaquage polyester noir de forge. Ancrage recommandé : Par quatre boulons à expansion M8.

Steel treated with Ferrus, a protective process for iron that guarantees high corrosion resistance. Epoxy primer coating and black wrought iron coloured polyester powder coated finish. Recommended anchoring: Four M8 expansion bolts.

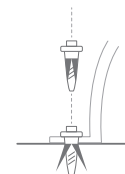
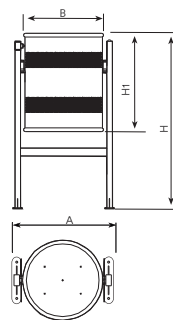

Ref.		A	Ø B	H	H1
PA606	70L.	545 mm	440 mm	950 mm	520 mm

*Opcional | En Option | Optional



Vida XXI

By BENITO © ©

Cubeta abatible y estructura de acero zincado electrolítico por inmersión con una posterior capa de imprimación epoxi y pintura en poliéster al horno. Color negro forja. Incorpora una iconografía. Base de anclaje y pletinas rectangulares con 2 agujeros de Ø12 mm para su fijación en el suelo. Anclaje recomendado: Mediante cuatro pernos de expansión de M8.

Corbeille basculante et structure en acier zingué électrolytique par immersion avec application ultérieure d'une couche primaire époxy et d'une peinture polyester au four. Teinte noir de forge avec icône fonctionnelle. Base d'ancrage et plats rectangulaires avec 2 trous de Ø 12 mm pour la fixation au sol. Ancrage recommandé : par quatre boulons à expansion M8.

Hinged bin and structure made of steel electro-galvanised by immersion, with epoxy primer and oven-baked polyester powder coated finish. Black wrought iron colour. Includes graphic symbol. Anchoring base and rectangular sheets with two Ø12 mm holes to fix it to the ground. Recommended anchoring: Four M8 expansion bolts.

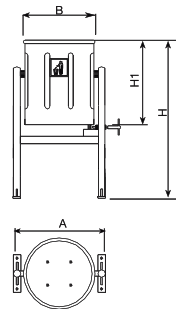
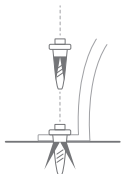

Ref.		A	Ø B	H	H1
PA679	40L.	485 mm	380 mm	840 mm	450 mm

*Opcional | En Option | Optional





*VC4GR

PA600M

PA600MI

Pies reforzados
Pieds reforcés
Reinforced gusset plates

Bloqueo de seguridad
Buttor de sécurié
Security locking system

Fácil vaciado
Facile vidage
Easy emptying



CIRCULARKIT

Circular

By BENITO © ©



Cubeta abatible de acero con agujeros triangulares con tratamiento Ferrus, proceso protector del hierro, que garantiza una óptima resistencia a la corrosión. Imprimación epoxi y pintura poliéster en polvo color gris RAL 7011 (PA600M). Cubeta apoyada en estructura de tubo de Ø40 mm con base de anclaje y pletinas rectangulares con dos agujeros de Ø12 mm para su fijación en el suelo. Anclaje recomendado: Mediante cuatro pernos de expansión de M8. Opcional: Acero inoxidable pulido brillante (PA600MI).

Corbeille basculante en acier perforé à motifs triangulaires traité avec Ferrus, un procédé qui protège le fer et garantit une résistance optimale à la corrosion. Couche primaire époxy et peinture poudre polyester de couleur gris RAL 7011 (PA600M). Corbeille qui repose sur une structure en tube de Ø 40 mm avec base d'ancrage et plats rectangulaires munis de deux trous de Ø 12 mm pour être fixée au sol. Ancrage recommandé : Par quatre boulons à expansion M8. En option : Acier inoxydable poli brillant (PA600MI).

Stainless steel tipping bin with triangular holes, treated with Ferrus, a protective process for iron that guarantees high resistance to corrosion. Epoxy primer and grey RAL 7011 polyester powder coating paint (PA600M). Bin supported on a Ø40 mm tube structure with an anchor base and rectangular bars with two Ø12 mm holes for fixing to the ground. Recommended anchoring: Four M8 expansion bolts. Optional: Shiny, polished stainless steel (PA600MI).

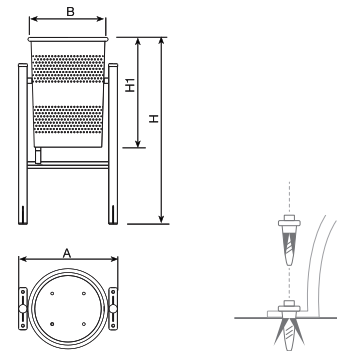

Ref.		A	Ø B	H	H1
PA600M	60L.	465 mm	375 mm	885 mm	525 mm
PA600MI	60L.	465 mm	375 mm	885 mm	525 mm

*Opcional | En Option | Optional

Semi-circular

By BENITO © ©

Cubeta semi-circular abatible de acero con agujeros triangulares con tratamiento Ferrus, proceso protector del hierro, que garantiza una óptima resistencia a la corrosión. Imprimación epoxi y pintura poliéster en polvo gris RAL 7011 (PA616M). Cubeta apoyada en estructura de tubo de Ø40 mm con base de anclaje y pletinas rectangulares con 2 agujeros de Ø12 mm para su fijación en el suelo. Anclaje recomendado: Mediante cuatro pernos de expansión de M8. Opcional: Acero inoxidable pulido brillante (PA616I)

Corbeille semi-circulaire basculante en acier perforé à motifs triangulaires traité avec Ferrus, un procédé qui protège le fer et garantit une résistance optimale à la corrosion. Couche primaire époxy et peinture poudre polyester de couleur gris RAL 7011 (PA616M). Corbeille qui repose sur une structure en tube de Ø 40 mm avec base d'ancrage et plats rectangulaires munis de deux trous de Ø 12 mm pour être fixée au sol. Ancrage recommandé : Par quatre boulons à expansion M8. En option : Acier inoxydable poli brillant (PA616I).

Semi-circular stainless steel litter bin with triangular holes, treated with Ferrus, a protective process for iron that guarantees high corrosion resistance. Epoxy primer and grey RAL 7011 polyester powder coating paint (PA616M). Bin supported on a Ø40 mm tube structure with an anchor base and rectangular bars with two Ø12 mm holes for fixing to the ground. Recommended anchoring: Four M8 expansion bolts. Optional: Shiny, polished stainless steel (PA616I).

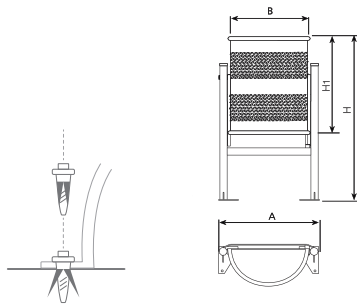

Fácil vaciado
Facile vidage
Easy emptying



Pies reforzados
Pieds reforcés
Reinforced gusset plates

Ref.		A	B	H	H1
PA616I	40L.	540 mm	455 mm	905 mm	540 mm
PA616M	40L.	540 mm	435 mm	905 mm	540 mm

*Opcional | En Option | Optional

Circular plus



Cubeta abatible de acero con agujeros de Ø5 mm zincado electrolítico por inmersión con una posterior capa de imprimación y pintura en poliéster al horno. Color gris RAL 7011. Cubeta apoyada en estructura de tubo de Ø40 mm con base de anclaje y pletinas rectangulares con dos agujeros de Ø12 mm para su fijación en el suelo. Anclaje recomendado: Mediante cuatro pernos de expansión de M8.

Corbeille basculante en acier perforé (trous de Ø 5 mm), zingage électrolytique par immersion avec application ultérieure d'une couche primaire époxy et d'une peinture polyester au four. Couleur gris RAL 7011. Corbeille reposant sur une structure en tube de Ø 40 mm avec base d'ancrage et plats rectangulaires munis de deux trous de Ø 12 mm pour la fixation au sol. Ancrage recommandé : par quatre boulons à expansion M8.

Steel hinged bin with Ø5 mm holes, electro-galvanised by immersion, with a primer coat and an oven-baked polyester coat. RAL 7011 grey. Bin supported by a Ø40 mm tubular structure with an anchoring base, which has rectangular sheets with two Ø12 mm holes to fix it to the ground. Recommended anchoring: Four M8 expansion bolts.

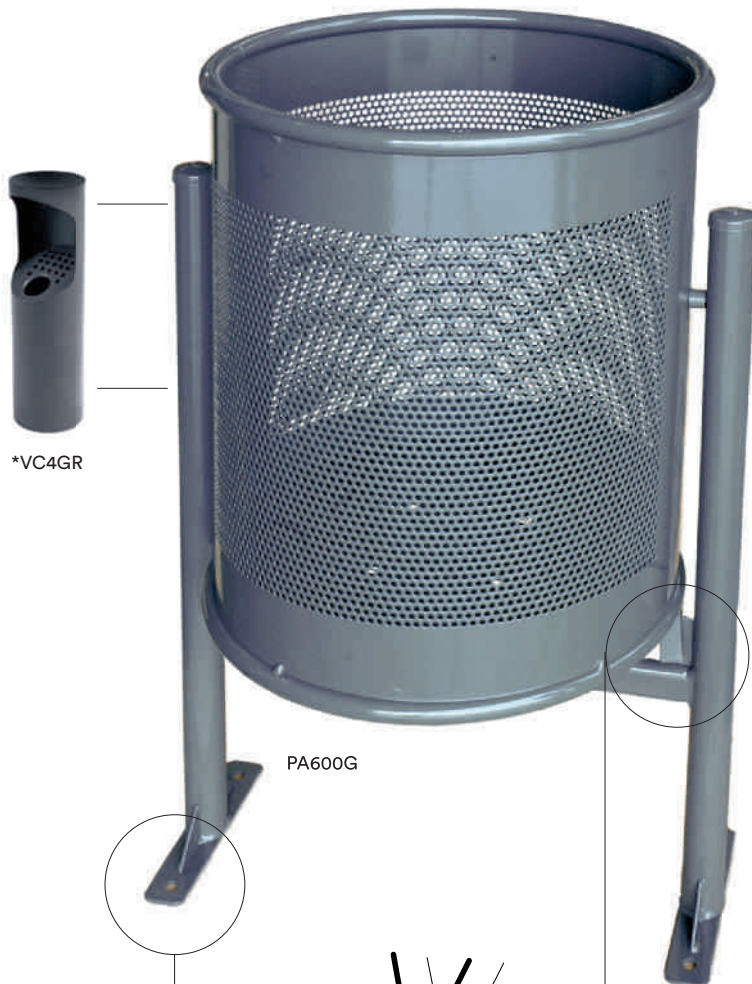

*VC4GR

PA600G

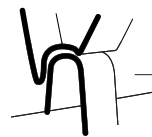

Bloqueo de seguridad
Buttor de sécurité
Security locking system

Fácil vaciado
Facile vidage
Easy emptying

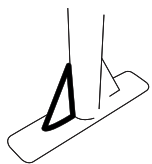

Pies reforzados
Pieds reforcés
Reinforced gusset plates

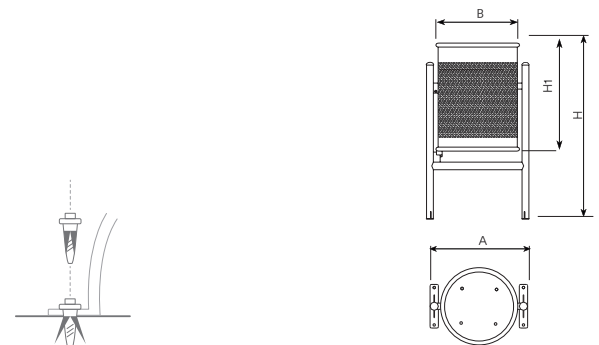
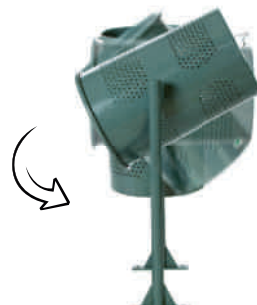

Ref.		A	Ø B	H	H1
PA600G	70L.	540 mm	435 mm	885 mm	540 mm

*Opcional | En Option | Optional



Basculante

Cubeta cilíndrica embutida y poste de Ø 60 mm de acero galvanizado, imprimación epoxi y pintura poliéster en polvo color negro forja. Anclaje recomendado: Mediante empotramiento en el suelo. Opcional: Con sombrero.

Corbeille cylindrique en tôle emboutie et poteau de Ø 60 mm en acier galvanisé, couche primaire époxy et thermolaquage polyester noir de forge. Ancrage recommandé : encastrement dans le sol. En option : avec protège-pluie.

Built-in cylindrical bin and Ø 60 mm galvanised steel post with epoxy primer coating and black wrought iron coloured polyester powder coated finish. Recommended anchoring: Embedded in the ground. Optional: Lid available.

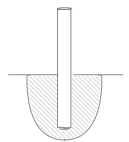
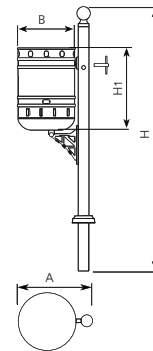

Otros productos Basculante
Autres produits Basculante
Other Basculante range products



P.95

Ref.		A	Ø B	H	H1
PA623	32L.	400 mm	320 mm	1465 mm	460 mm
PA623D	2×32L.	738 mm	320 mm	1465 mm	460 mm
PA623S	32L.	400 mm	320 mm	1465 mm	460 mm
PA623DOS	2×32L.	738 mm	320 mm	1465 mm	460 mm
PA623P	30L	410 mm	320 mm	750 mm	460 mm

*Opcional | En Option | Optional

Basculante selectif

Cubeta cilíndrica galvanizada con imprimación epoxi y pintura poliéster en polvo color negro forja para el poste, una cubeta en amarillo RAL 1021 y una cubeta en azul RAL 5012. Poste para su fijación en tubo de acero. Anclaje recomendado: Mediante empotramiento en el suelo. Opcional: Con tapa

Corbeille cylindrique en tôle galvanisée avec couche primaire époxy et thermolaquage polyester pied noir de forge pour le poteau, une corbeille jaune RAL 1021 et une corbeille bleue RAL 5012. Poteau de fixation en tube d'acier. Ancrage recommandé : par encastrement dans le sol. En option : Avec couvercle.

Galvanised cylindrical bin with an epoxy primer coating and a black wrought iron coloured polyester powder coated finish; one bin in yellow RAL 1021 and another in blue RAL 5012. Post to be attached to a steel tube. Recommended anchoring: Embedded in the ground. Optional: With lid.

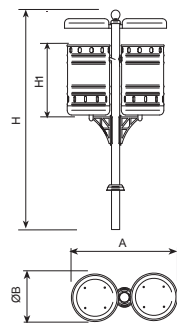
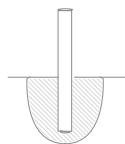

Ref.		A	Ø B	H	H1
PA623DS	2x32L.	745 mm	320 mm	1480 mm	460 mm
PA623DSS	2x32L.	745 mm	320 mm	1480 mm	460 mm

Fácil vaciado
Facile vidage
Easy emptying





PA611



Fácil vaciado
Facile vidage
Easy emptying

Otros productos Gavarres
Autres produits Gavarres
Other Gavarres range products



P.68-69

P.68-69

P.68-69

P.68-69

P.68-69

P.190

Gavarres

By Martí Franch © BENITO



Estructura de acero corten de 6 mm, tablonces de madera de pino tratada en autoclave vacío-presión clase 4 contra la carcoma, termitas e insectos. Cubeta interior de acero galvanizado. Anclaje recomendado: Mediante pernos.

Sabías que... la madera natural "respira" és decir, absorbe y desprende la humedad en ambiente seco. Por lo tanto, és normal que puedan aparecer grietas en la madera. No influencia para nada en su capacidad de resistencia y su durabilidad.

Structure en acier Corten de 6 mm et lattes de bois de pin traités en autoclave sous vide d'air (classe 4 contre les vers à bois, les termites et les insectes). Corbeille intérieure en acier galvanisé. Ancrage recommandé : par boulonnage.

Saviez vous que... le bois naturel "respire", c'est-à-dire, qu'il absorbe et restitue de l'humidité dans une atmosphère sèche. Il est par conséquent normal que des fissures apparaissent dans le bois. Ceci n'influence en rien sa capacité de résistance et sa durabilité.

6 mm Corten steel structure, pinewood boards vacuum-pressure treated in an autoclave against woodworm, termites and insects. Galvanised steel inner bin. Recommended anchoring: bolts.

Did you know... natural wood "breathes" i.e. it absorbs humidity and releases it in dry atmospheres. It is therefore normal for cracks to appear in wood. This has no effect whatsoever on its strength and durability.

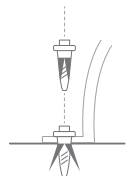
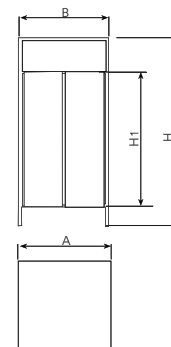

Ref.		A	B	H	H1
PA611	110L.	440 mm	460 mm	1000 mm	670 mm



Salou

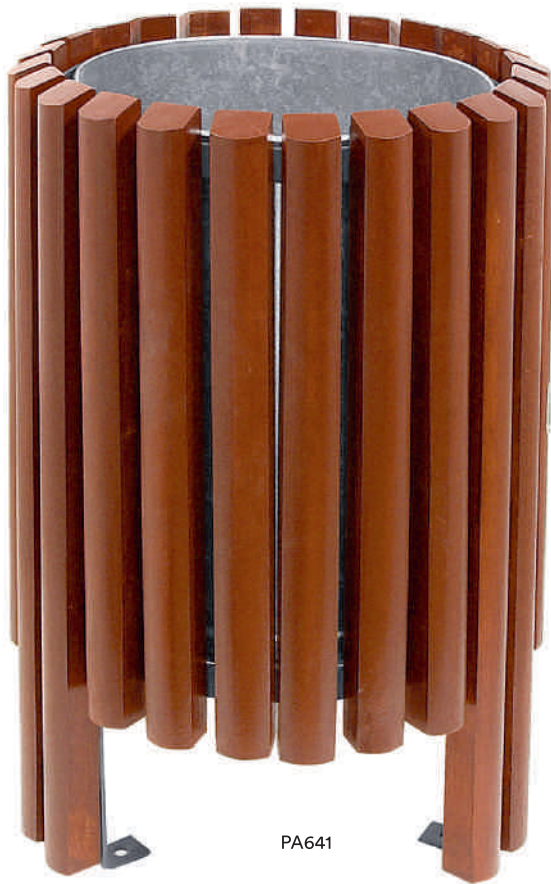

Estructura interior metálica y estructura exterior con veinticuatro listones de madera para exterior de sección 40x35 mm tratada con Lignus, protector fungicida, insecticida e hidrófugo. Acabado color caoba. Cubeta de acero galvanizado. Anclaje recomendado: Mediante tres pernos de expansión de M8.

Structure intérieure métallique, extérieure avec vingt-quatre lattes en bois tropical, de section 40 x 35 mm, traité avec Lignus, protecteur fongicide, insecticide et hydrofuge. Finition teinte acajou. Corbeille en acier galvanisé. Ancre recommandé : par trois boulons à expansion M8.

Inner and outer metal structure of twenty-four 40x35 tropical wood slats for outdoor use treated with Lignus, a fungicide, insecticide and waterproofing agent. Mahogany colour finish. Galvanised steel bin. Recommended anchoring: Three M8 expansion bolts.

Fácil vaciado
Facile vidage
Easy emptying

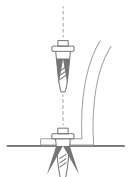
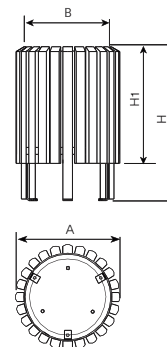

Ref.		Ø A	Ø B	H	H1
PA641	40L.	460 mm	-	700 mm	545 mm

Rustica

Madera de pino con tratamiento autoclave a vacío-presión clase 4 contra la carcoma, termitas e insectos. Acabado color natural. Tornillería en acero inoxidable. Anclaje recomendado: Mediante tres pernos de expansión de M8.

Sabias que... la madera natural "respira" és decir, absorbe y desprende la humedad en ambiente seco. Por lo tanto, és normal que puedan aparecer grietas en la madera. No influencia para nada en su capacidad de resistencia y su durabilidad. P. 10

Pin avec traitement autoclave à vide - pression classe 4 contre les vers à bois, les termites et les insectes. Finition teinte naturelle. Vis en acier inoxydable. Ancrage recommandé : par trois boulons à expansion M8.

Saviez vous que... le bois naturel "respire", c'est-à-dire, qu'il absorbe et restitue de l'humidité dans une atmosphère sèche. Il est par conséquent normal que des fissures apparaissent dans le bois. Ceci n'influence en rien sa capacité de résistance et sa durabilité. P. 10

Pine wood vacuum-pressure treated in an autoclave against woodworm, termites and insects. Natural colour finish. Hardware in stainless steel. Recommended anchoring: Three M8 expansion bolts.

Did you know... natural wood "breathes" i.e. it absorbs humidity and releases it in dry atmospheres. It is therefore normal for cracks to appear in wood. This has no effect whatsoever on its strength and durability. P. 10

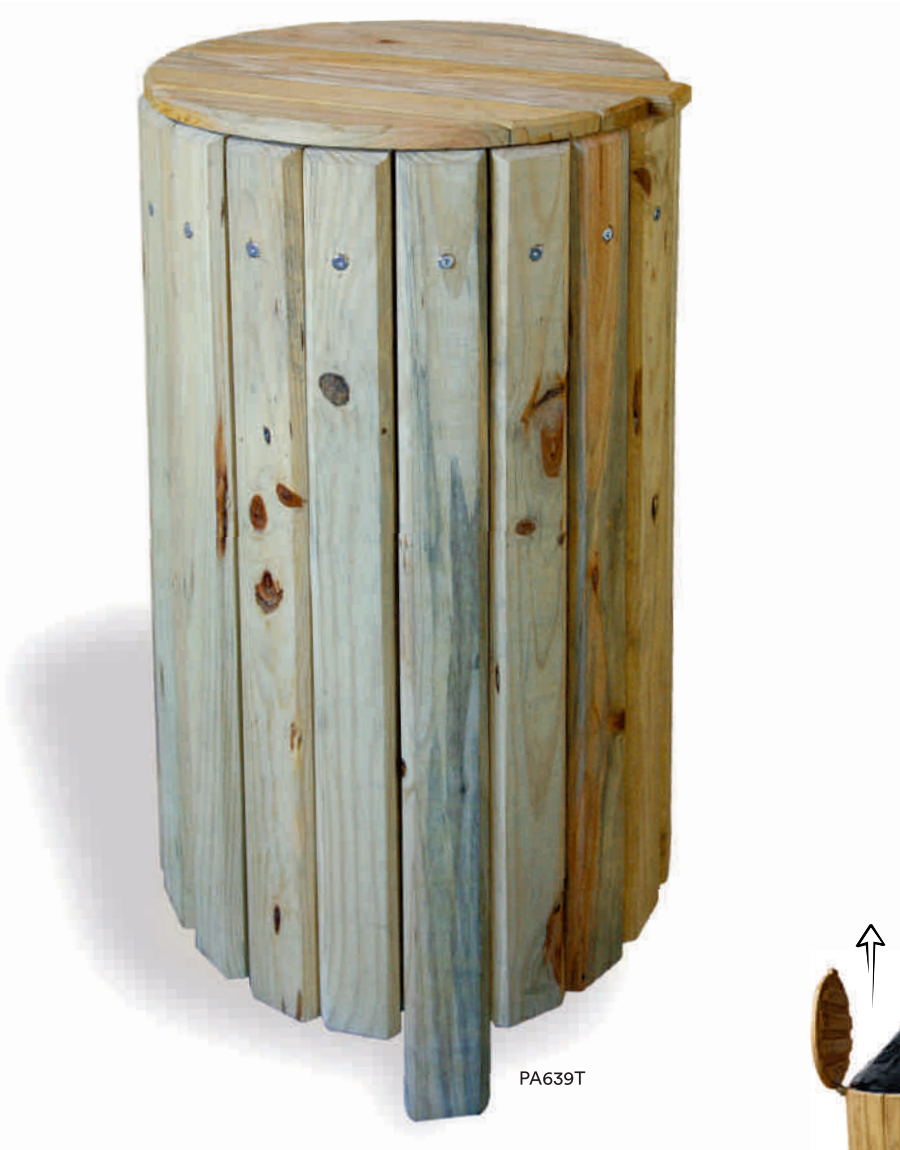

PA639T



Fácil vaciado
Facile vidage
Easy emptying

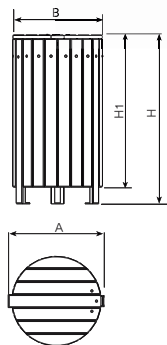

Otros productos en madera de pino
Autres produits en pin
Other products made of pinewood



P.70-71

P.124-125

P.152-153

P.192

P.180-181

P.180-181

P.180-181

Ref.		A	Ø B	H	H1
PA639T	90L.	520 mm	480 mm	910 mm	820 mm

Tulipa



PA635

Acero zincado electrolítico por inmersión con una posterior capa de imprimación epoxi y pintura en poliéster al horno color verde RAL 6005. Cubeta de acero galvanizado. Anclaje recomendado: Mediante tres pernos de expansión de M8.

Acier zingué électrolytique par immersion avec application ultérieure d'une couche primaire époxy et d'une peinture polyester au four. Couleur vert RAL 6005. Corbeille en acier galvanisé. Ancrage recommandé : par trois boulons à expansion M8.

Steel electro-galvanised by immersion with epoxy primer coating and oven-baked polyester coating. Green RAL 6005. Galvanised steel bin. Recommended anchoring: Three M8 expansion bolts.

Fácil vaciado
Facile vidage
Easy emptying

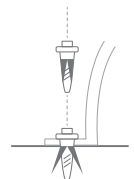
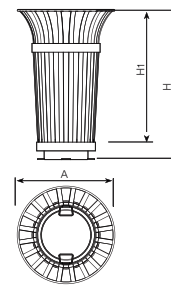

Ref.		Ø A	B	H	H1
PA635	50L.	560 mm	-	850 mm	800 mm





PA672S

PA672

Fácil vaciado
Facile vidage
Easy emptying

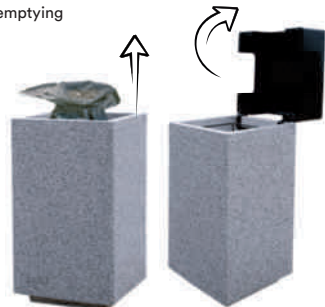

Kube



Hormigón prefabricado color gris granítico de aspecto liso. Aro para fijar la bolsa de acero zincado con imprimación epoxi y pintura poliéster en polvo color negro. Anclaje recomendado: Apoyado por su propio peso. Opcional: Con tapa.

Béton préfabriqué gris granite, aspect lisse. Anneau pour fixer le sac plastique en acier zingué avec couche primaire époxy et thermolaquage polyester noir. Ancrage recommandé : Posé à terre. En option : Avec couvercle.

Pre-cast smooth granite grey concrete. Ring to hold the bag made of galvanised steel with epoxy primer coating and black paint. Recommended anchoring: free-standing. Optional: With lid.

Otros productos Kube
Autres produits Kube
Other kube range products



P.40-41

P.40-41

P.44-45

P.44-45

P.38-39

P.40-41

P.38-39

P.44-45

P.44-45

P.151

P.151

P.123

P.196

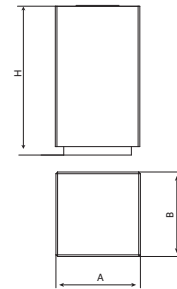

Ref.		A	B	H
PA672	140L.	500 mm	500 mm	880 mm
PA672S	140L.	500 mm	500 mm	1085 mm

Kube selectif

Hormigón prefabricado color gris granítico de aspecto liso. Aros para fijar la bolsa, de acero zincado con imprimación epoxi y pintura poliéster en polvo color negro con color específico para cada tipo de residuo: papel, envases, orgánico, vidrio. Apoyado por su propio peso

Béton préfabriqué gris granite, d'aspect lisse. Anneau pour fixer le sac, en acier zingué avec apprêt époxy et peinture polyester en poudre de couleur noire, couleur spécifique pour chaque type de résidu: papier, plastiques, organique et verre. Ancrage recommandé : Posé à terre.

Pre-cast smooth granite grey concrete. Ring to fix the bag made of galvanised steel with epoxy primer coating and black colour with a specific colour for each type of waste: paper, packages, organic or glass. Recommended anchoring: free-standing.

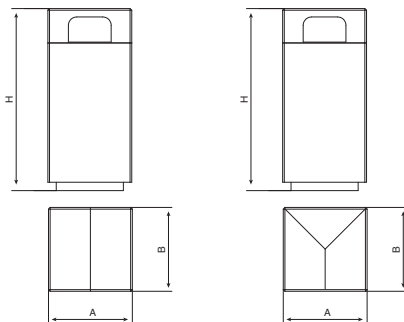

Ref.		A	B	H
PA672S2	70L+70L	500 mm	500 mm	1085 mm
PA672S3	55L+55L+30L	500 mm	500 mm	1085 mm
PA672SA	140L.	500 mm	500 mm	1085 mm
PA672SAZ	140L.	500 mm	500 mm	1085 mm
PA672SM	140L.	500 mm	500 mm	1085 mm
PA672SV	140L.	500 mm	500 mm	1085 mm

*Opcional | En Option | Optional

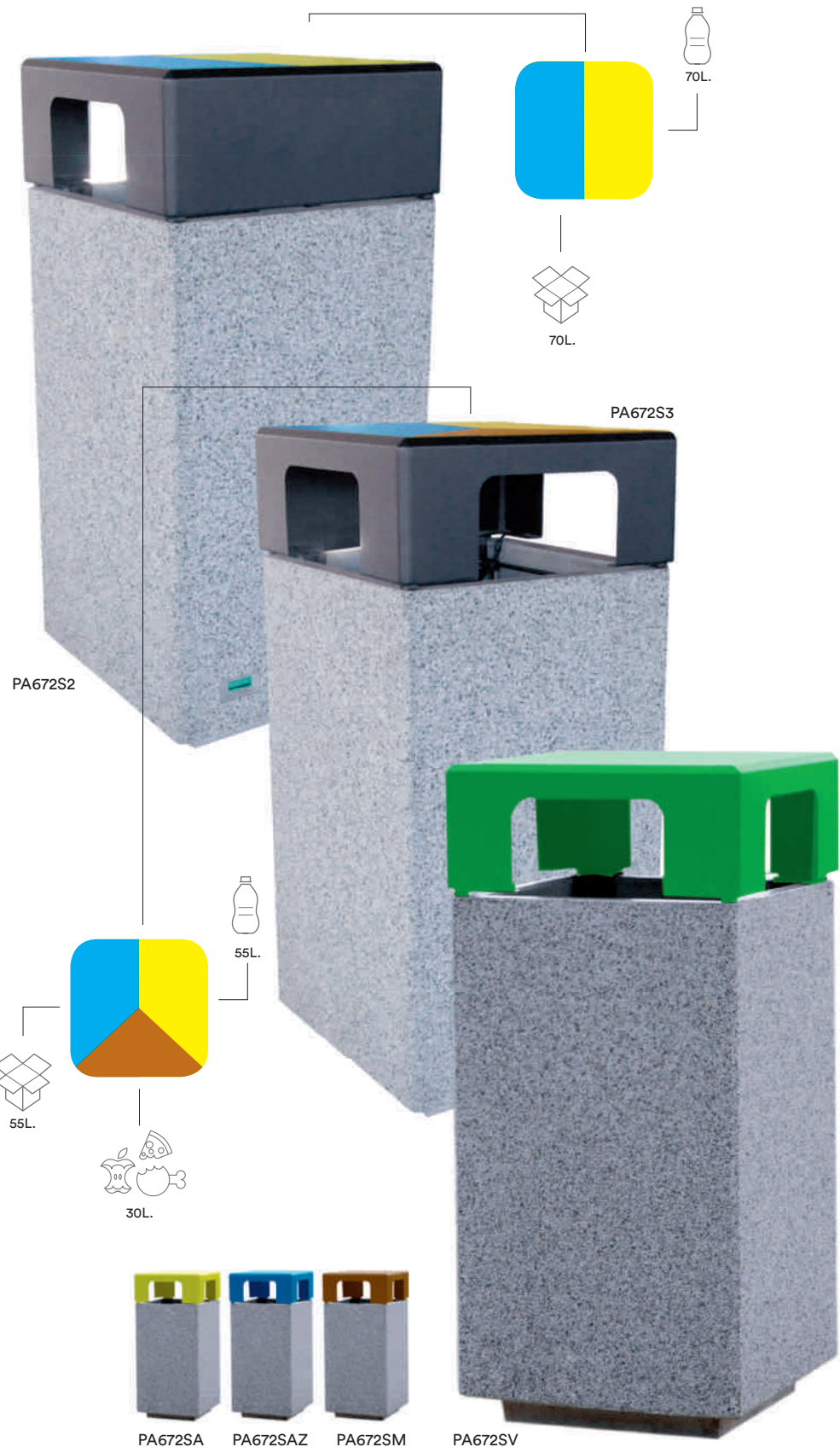

Fija aro

Cubeta de acero con agujeros de 5 mm de diámetro, zincada electrolítico por inmersión con una posterior capa de imprimación epoxi y pintura en poliéster al horno. Color gris RAL 7011. Cubeta provista de un aro para fijar la bolsa. Anclaje recomendado: Mediante tres pernos de expansión M8. Opcional: boca superior con color específico para cada tipo de residuo: papel, embases, vidrio... También opción con tapa.

Corbeille en acier perforé (trous de \varnothing 5 mm), zingage électrolytique par immersion avec application ultérieure d'une couche primaire époxy et d'une peinture polyester au four. Couleur gris RAL 7011. Anneau pour fixer le sac plastique. Ancrage recommandé : par trois boulons à expansion M8. En option : collecteur supérieur avec couleur spécifique pour chaque type de déchet : papiers, plastiques, verre... Possible également avec couvercle.

Steel bin with \varnothing 5 mm holes, electro-galvanised by immersion, with an epoxy primer coat and an oven-baked polyester coat. RAL 7011 grey. The bin is equipped with a ring to hold the bag. Recommended anchoring: Three M8 expansion bolts. Optional: Top opening with a specific colour for each type of waste: paper, plastic, glass, etc. Also available with a lid.

PA620T

PA620

Fácil vaciado
Facile vidage
Easy emptying



Otros productos Fija Aro Selectif
Autres produits Fija Aro Selectif
Other Fija Aro Selectif range products

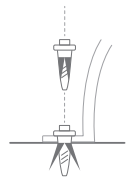
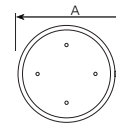
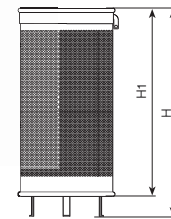
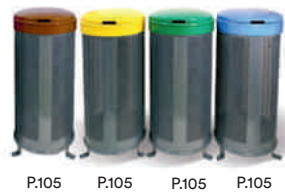

Ref.		\varnothing A	B	H	H1
PA620	110L.	435 mm	-	930 mm	860 mm
PA620T	110L.	435 mm	-	975 mm	860 mm

Fija aro selectif

Cubeta de acero con agujeros de 5 mm de diámetro zincada electrolítico por inmersión con una posterior capa de imprimación epoxi y pintura en poliéster al horno. Cuerpo color gris RAL 7011. Cubeta provista de un aro para fijar la bolsa. Boca superior con color específico para cada tipo de residuo: papel, envases, vidrio... Anclaje recomendado: Mediante tres pernos de expansión M8. Opcional: Con tapa.

Corbeille en acier perforé (trous de Ø 5 mm), zingage électrolytique par immersion avec application ultérieure d'une couche primaire époxy et d'une peinture polyester au four. Corps de couleur gris RAL 7011. Anneau pour fixer le sac plastique. Collecteur supérieur avec couleur spécifique pour chaque type de déchet : papiers, plastiques, verre... Ancrage recommandé : par trois boulons à expansion M8. En option : Avec couvercle.

Steel bin with Ø5 mm holes, electro-galvanised by immersion with an epoxy primer coat and an oven-baked polyester coat. Body in grey RAL 7011. The bin is equipped with a ring to hold the bag. Top opening with a specific colour for each type of waste: paper, plastic, glass, etc. Recommended anchoring: Three M8 expansion bolts. Optional: With lid

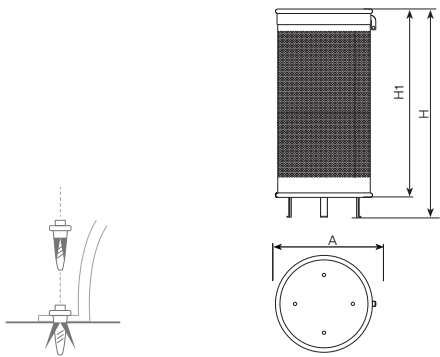

Ref.		Ø A	B	H	H1
PA620A	RAL1021	110L. 435 mm	-	930 mm	860 mm
PA620AZ	RAL5012	110L. 435 mm	-	930 mm	860 mm
PA620V	RAL6029	110L. 435 mm	-	930 mm	860 mm
PA620M	RAL8024	110L. 435 mm	-	930 mm	860 mm
PA620TA	RAL1021	110L. 435 mm	-	975 mm	860 mm
PA620TAZ	RAL5012	110L. 435 mm	-	975 mm	860 mm
PA620TV	RAL6029	110L. 435 mm	-	975 mm	860 mm
PA620TM	RAL8024	110L. 435 mm	-	975 mm	860 mm

Deployee

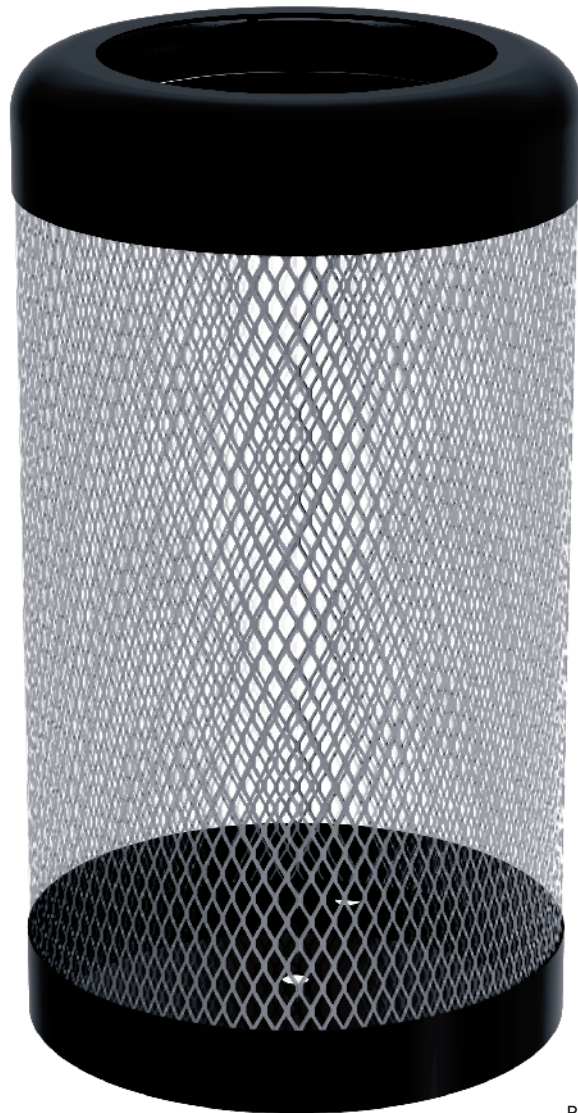

PA638

Papelera cilíndrica de gran capacidad para centros comerciales, aeropuertos, hoteles...

Cabezal y base de chapa de acero galvanizado y cuerpo de plancha deployee. Aro interior para la sujeción de la bolsa. Tapa abisagrada con cierre triangular. Color: base y cabezal con pintura poliéster color negro RAL-9005 y chapa deployee color gris RAL-9006.

Poubelle cylindrique de grande capacité pour centres commerciaux, aéroports, hôtels...

Tête et base en acier galvanisé et corps en tôle deployee. Anneau intérieur pour la fixation du sac. Couvercle biseauté avec fermeture triangulaire. Couleur: base et tête peinture polyester couleur noire RAL-9005 et tôle deployee couleur grise RAL-9006.

Cylindrical bin with big capacity for malls, airports, hotels...

Top and base parts made of galvanised steel and body made of deployee steel. Inner ring to hold the bag. Hinged lid with triangular lock. Colour: base and top parts powder coated in black RAL 9005 polyester finish and deployee RAL-9006 grey coloured metal sheet.

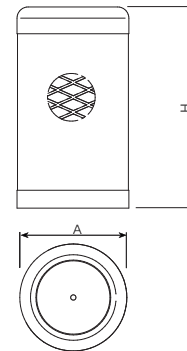

Ref.		Ø A	B	H	H1
PA638	140L.	500 mm	-	900 mm	-

Ibiza

Papelera de polietileno coloreado en masa y tratado contra radiaciones ultravioletas. Cubeta interior de polietileno. Vaciado y mantenimiento: apertura de la puerta frontal y retirada de la cubeta por la cara delantera. Mecanismo de cierre con llave. Color estandar: gris.

*Opcional con un pedido mínimo de 30 unidades:
- Cenicero en la parte superior de la tapa.

Poubelle en polyéthylène teintée en masse et traitée contre les rayons ultraviolets. Réceptacle intérieur en polyéthylène. Vidage et maintenance: ouverture de la porte frontale et extraction du réceptacle par la face frontale. Mécanisme de fermeture avec clé. Couleur standard: gris.

*Optionnel avec commande minimale de 30 unités:
- Cendrier sur la partie supérieure du couvercle.

Litter bin made of mass-coloured polyethylene and treated against UV radiation. Inner liner made of polyethylene. Emptying and maintenance: open the front door to remove of inner liner. Key lock mechanism. Standard colour: grey.

*Optional with minimum order quantity: 30 pc:
- Ashtray on the top part of the lid.

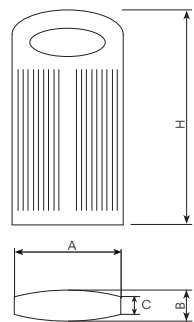

Ref.		A	B	C	H
PA660	80L.	595 mm	395 mm	125 mm	1070 mm

PA660



Fácil vaciado
Facile vidage
Easy emptying



Olea

By BNT Team BENITO

PA651



PA655

* Acabado imprimación epoxi y pintura poliéster en polvo color MARSON.

* Finition couche primaire époxy et thermo-laquage polyester teinte MARSON.

* Epoxy primer coating and MARSON polyester powder coated finish.

Papeleras de chapa de acero corten. Concebida para permanecer en el tiempo sin ningún tipo de mantenimiento. Aro interior para sujeción de la bolsa. Evita procesos contaminantes y contribuye a la sostenibilidad del medioambiente.

Nota: La oxidación del acero corten evoluciona con el paso del tiempo y se oxida, más o menos rápido, en función de la temperatura ambiente y la humedad. P. 08

Poubelles en acier Corten. Conçues pour durer sans aucun type de maintenance. Arceau intérieur pour fixer le sac. Évite les processus contaminants et contribue au respect de l'environnement.

Note: L'oxydation de l'acier évoluera au fil du temps, et sera plus ou moins rapide en fonction de la température ambiante et de l'humidité. P. 08

Bins made of Corten steel sheet. Designed to last maintenance-free over time. Inner ring to hold the bag. Needs no finish, which eliminates processes that pollute the environment, contributing to sustainability.

Note: the rustiness from Corten steel evolves overtime, which means that this material sooner or later will get rusty depending on the humidity and temperature levels. P. 08

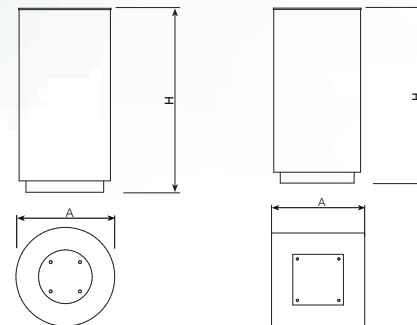

Otros productos Olea
Autres produits Olea
Other Olea range products



P.66-67



P.66-67



P.66-67



P.66-67



P.142



P.142



P.118



P.191

Ref.		Ø / ∅ A	B	H	H1
PA651	85L.	405 mm	-	806 mm	-
PA655	108L.	405 mm		806 mm	

*Opcional | En Option | Optional



Doria



PA686

La papelera Doria está destinada a la separación, del material reciclable. Incorpora cenicero. El cuerpo de la papelera es de chapa de acero de 2mm, con aro de refuerzo. Tapa superior de acero inoxidable AISI304, con 3 agujeros de 185 mm de diámetro, lo que impide que la gente pueda tirar las bolsas de basura doméstica. Cierre antivandálico de triángulo automático. Sistema de sujeción interior para las bolsas y separadores de chapa galvanizada. Tratamiento por cataforesis del cuerpo de la papelera y pintura al horno en oxirón negro.

Instalación : fijación al pavimento con 3 tacos metálicos de expansión M10

La poubelle Doria est destinée à la séparation de déchets recyclables. Cendrier incorporé. Le corps de la poubelle est en tôle d'acier de 2mm, avec un arceau de renforcement dont l'extérieur est en tôle d'acier. Baguette de 8 mm sur la partie supérieure. Le couvercle est en acier inoxydable AISI304, avec 3 orifices de 185 mm de diamètre, pour éviter d'y jeter des sacs poubelle domestiques. Fermeture anti vandalisme triangulaire automatique. Système de fixation intérieure pour les sacs et séparateurs en tôle galvanisée.

Traitement par cataphorèse du corps de la poubelle et thermo laquage avec finition architectonique, oxirón noire. Installation : fixation au sol par 3 chevilles d'expansion métalliques M10

The Doria litter bin is specifically designed for the waste separation of recyclable material. Ashtray included. The body is made of 2mm steel sheet with a reinforced ring. It includes an 8 mm bar in the top part. The upper lid is made of AISI 304 stainless steel with 3 holes of 185mm diameter each, which prevents people from throwing garbage bags inside. Additional features: Anti-vandalism triangular lock, inner fixing system for bags and galvanised sheet separators.

Our Cataphoresis treatment has been applied to the body and it has black oxirón finish.

Installation: 3 expansion metallic sockets (M10)

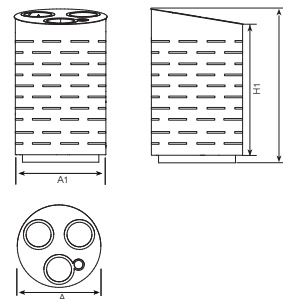

Ref.		Ø A	Ø A1	B	H	H1
PA686	3x75L.	620 mm	605 mm	-	1020 mm	920 mm



Acero | Acier | Steel



Corten

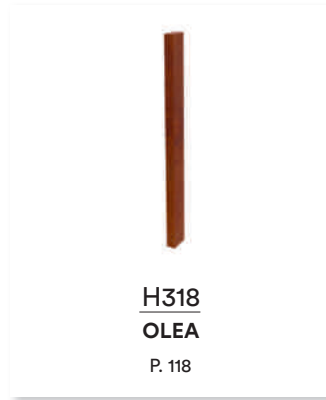

reBnew



Acero inoxidable | Acier inoxydable | Stainless steel



H253I
INOX
P. 134



H275
RETRACTABLE
P. 135



H275AHG
AUTOMATIC
P. 136-137

Hormigón | Béton préfabriqué | Concrete



H372
KUBE
P. 123



H250
PALAMOS
P. 124-125



H250A
PALAMOS
P. 124-125

Tráfico | Trafic | Traffic



H207M
DESMONTABLE
P. 128-129



H292
KROK
P. 130



H290
PARKING
P. 131

Dalia

By BENITO © ©

Acero zincado con imprimación epoxi y pintura poliéster en polvo color negro forja. Parte superior con embellecedor de acero inoxidable. Instalación: Base empotrable y varillas de rea con hormigón. Opcional: Con base extraíble (H314MB). Altura 1200 mm. Altura 1400 mm.

Acier zingúé avec couche primaire époxy et thermolaquage polyester noir de forge. Partie supérieure avec ornement en acier inoxydable. Installation: base à encastrer et tiges de fer avec béton. En option: avec base amovible (H314MB). Hauteur 1200 mm. Hauteur 1400 mm.

Galvanised steel with epoxy primer coating and black wrought iron coloured polyester powder coated finish. Stainless steel decorative top. Fitting: Embeddable base and bars with concrete. Optional: Removable base (H314MB). Height: 1200 mm. Height: 1400 mm.



H314-4



H314-2
H3142M/1



H314
H314M/1C



PL01



H314MB

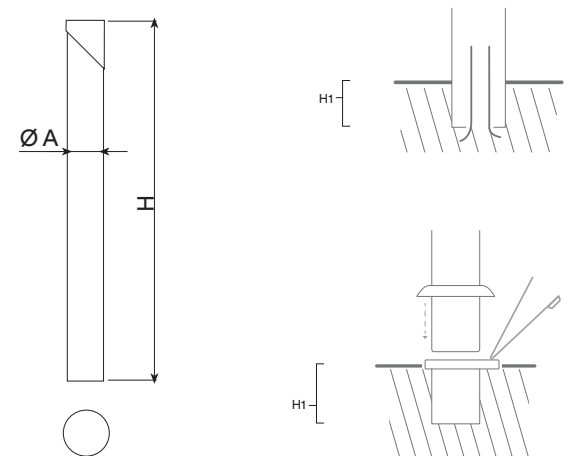

Ref.	Ø A	B	H	H1
H314	90 mm	-	1010 mm	-
H314M/1C	90 mm	-	975 mm	135 mm
H314-2	Ø90 mm	-	1200 mm	-
H314-2M/1	Ø90 mm	-	1200 mm	135 mm
H314-4	Ø90 m	-	1400 mm	-

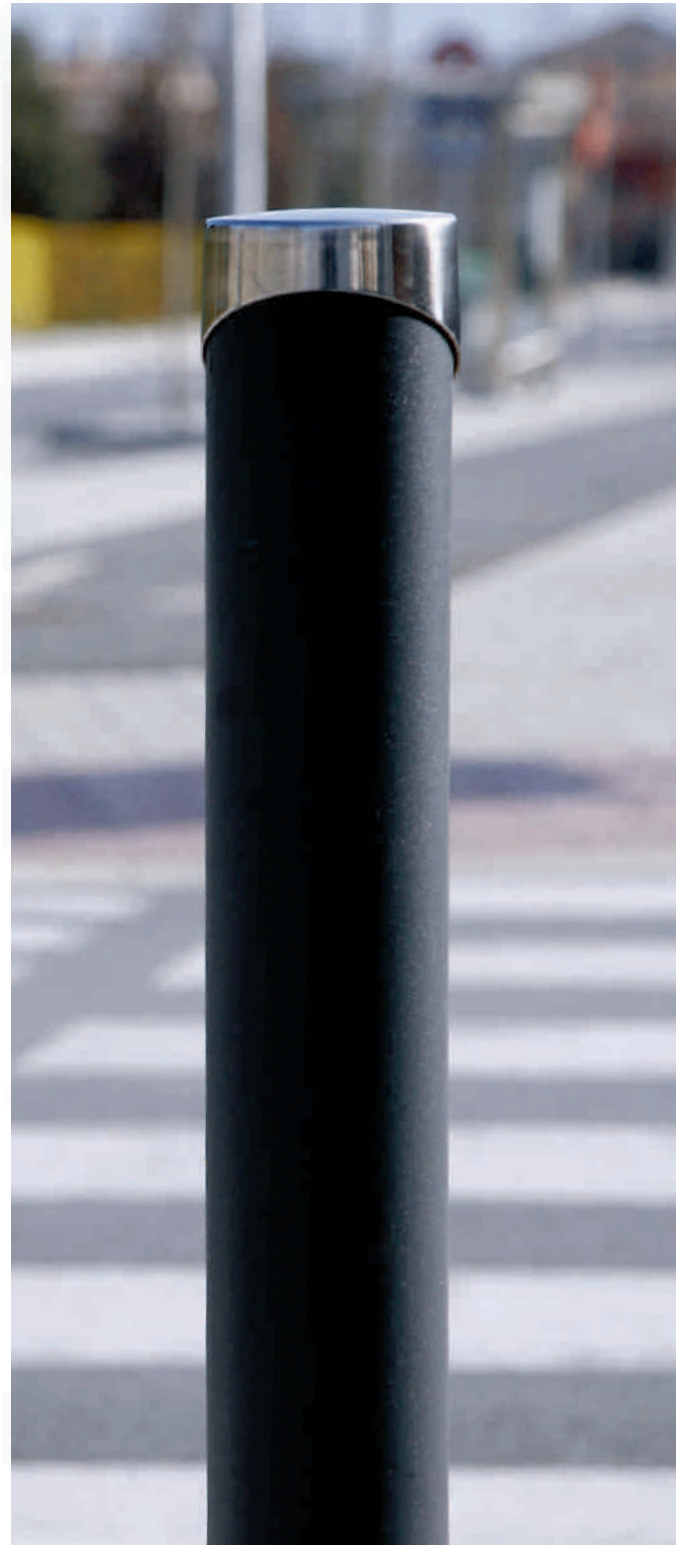

Dalia

DALIA es un producto muy eficiente pensado para el balizaje y señalización de caminos, parques y zonas peatonales.

Entre sus principales características destacan su robustez mecánica y resistencia a la corrosión.

Está fabricada en acero galvanizado en caliente. Con acabados superficial mediante imprimación epoxi y revestimiento de pintura poliéster al horno, en oxirón negro. La tapa superior es de acero inoxidable con pulido brillante, que la hace muy atractiva. El difusor es de metacrilato glaseado, que hace que la luz sea muy uniforme. El bloque óptico está integrado en la misma Baliza, siendo una pieza conjunta. Fácil mantenimiento incorporando una puerta de registro según EN40 y reglamento electrotécnico de baja tensión. Facilitando el cambio de lámpara únicamente quitando la tapa inoxidable de la parte superior.

Instalación: 4 pernos M16 . Opcional: Baliza Dalia LED IBDA-L100LED.

DALIA est un produit très efficace conçu pour le balisage et la signalisation des chemins, parcs et zones piétonnes.

Parmi ses principales caractéristiques, il faut souligner sa robustesse mécanique et sa résistance à la corrosion.

Elle est fabriquée en acier galvanisé à chaud. Avec une peinture polyester au four. Le couvercle supérieur est en acier inoxydable avec une finition polie brillante, qui la rend très attrayante. Le diffuseur est en méthacrylate lustré qui rend la lumière très uniforme. Le bloc optique est intégré dans la Balise même, formant une seule pièce.

Elle est conçue de façon à avoir un entretien facile, elle comprend une porte/regard conforme à l'EN40 et au règlement électrotechnique de basse tension, facilitant le changement de lampe, uniquement en enlevant le couvercle inoxydable de la partie supérieure.

Installation : 4 vis M16. En option : Balise Dalia LED IBDAL100LED.

The DALIA Beacon is a highly efficient product designed for lighting and marking paths, parks and pedestrian zones.

Highlights among its main features are its mechanical robustness and its resistance to corrosion.

It is made from hot galvanised steel, with the surfaces coated with epoxy primer and then painted with oven-cured black oxiron polyester. The top cover is bright polished stainless steel, making it highly attractive. The diffuser is in glazed methacrylate, making the light very uniform. The optical block is built into the Beacon itself to form an integrated unit. It is designed to be easy to maintain, featuring an inspection door in accordance with EN40 and low-voltage electrical regulations, making it easy to change the bulb simply by removing the stainless steel cover on the top. Fitting: 4 bolts M16. Optional: LED Dalia Beacon IBDAL100LED. .

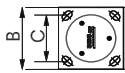
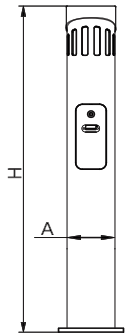

IBDAL100

Ref.	Ø A	B	C	H
IBDAL100	Ø140 mm	190 mm	140 mm	1000 mm

Clase I / Classe I / Class I			
Grado de protección / Degré de protection / Protection level	Potencia / Puisseance / Power	Casq. / Douille / Lamp holder	FC / FC / CF
IBDAL100	8W	E27	X
	14W	E27	X
IBDAL100LED	IP64		X

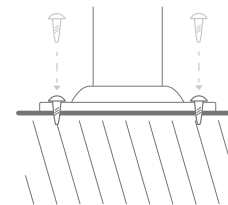

Lis

Baliza de LEDs elegante, robusta y bajo mantenimiento para aplicaciones de señalización e iluminación de caminos, parques y zonas peatonales. Está fabricada en acero galvanizado de 3mm de grueso y pintado al horno, acabado en negro texturado RAL9005 y otros colores bajo demanda. Fácil mantenimiento incorporando una puerta de registro según EN40 y reglamento electrotécnico de baja tensión. Instalación: 4 pernos M12.

LED Built-in CoB

- 3000oK 996lm | 4000oK 1050lm
- CRI>80
- Potencia absorbida 15W
- Vin 220-240Vac 50/60Hz
- Alto factor de potencia >0,95
- Vida útil 50.000h (L70/B50)
- Clase I

Balise LEDs élégante, robuste et de bas entretien pour applications de signalisation et d'éclairage des chemins, parcs et zones piétonnes.

Elle est fabriquée en Acier galvanisé de 3mm d'épaisseur, peint au four, finition en noir texturé RAL9005 et autres coloris sur demande. Elle est conçue de façon à avoir un entretien facile, elle comprend une porte/regard conforme à l'EN40 et au règlement électrotechnique de basse tension. Installation : 4 vis M12.

LED Built-in CoB

- 3000oK 996lm | 4000oK 1050lm
- CRI>80
- Puissance absorbée 15W
- Vin 220-240Vac 50/60Hz
- Haut facteur de puissance >0,95
- Vie utile 50.000h (L70/B50)
- Classe I

LIS is a very efficient product specially designed to mark pathways, parks and pedestrian zones.

This is an elegant, robust and low maintenance LED beacon for path marking and lighting applications.

Made of 3 mm galvanised steel and lacquered in epoxy painting with a textured RAL9005 black finish. Other colours available on demand. It provides easy maintenance and comes with an intake door according to the EN40 and low tension electrotechnical regulations. Installation: 4 M12 bolts .

LED Built-in CoB

- 3000oK 996lm | 4000oK 1050lm
- CRI>80
- Input power 15W
- Vin 220-240Vac 50/60Hz
- High input power factor >0,95
- Lifespan 50.000h (L70/B50)
- Class I

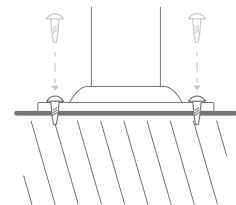
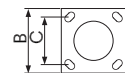
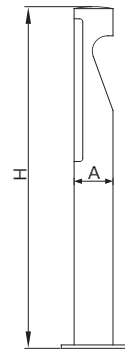

Ref.	Ø A	B	C	H
IBLI100LED15K4	Ø114 mm	190 mm	140 mm	1000 mm
IBLI100LED15K3	Ø114 mm	190 mm	140 mm	1000 mm



H318



* Acabado imprimación epoxi y pintura poliéster en polvo color MARSON.

* Finition couche primaire époxy et thermolaquage polyester teinte MARSON.

* Epoxy primer coating and MARSON polyester powder coated finish.

Olea

By BNT Team BENITO

Pilona de Acero Corten de 50 × 100 mm, concebida para permanecer en el tiempo sin ningún tipo de mantenimiento. No necesita ningún acabado, evita procesos contaminantes y contribuye a la sostenibilidad medioambiental. Instalación: Base empotrable y varillas de rea con hormigón.

Nota: La oxidación del acero corten evoluciona con el paso del tiempo y se oxida, más o menos rápido, en función de la temperatura ambiente y la humedad.

Bornes d'acier Corten de 50 × 100 mm, conçue pour durer très longtemps sans aucun type d'entretien. Ne requérant aucune finition, elle permet d'éviter les processus polluants en contribuant ainsi à la durabilité de l'environnement. Installation: Base à encastrer et tiges filetées avec béton.

Note: L'oxydation de l'acier évoluera au fil du temps, et sera plus ou moins rapide en fonction de la température ambiante et de l'humidité.

Bollard in 50 × 100 made from Corten steel, designed to last maintenance-free over time. Needs no finish, which eliminates processes that pollute the environment, contributing to sustainability. Fitting: Embeddable base and bars with concrete.

Note: the rustiness from Corten steel evolves overtime, which means that this material sooner or later will get rusty depending on the humidity and temperature levels.

Otros productos Olea
Autres produits Olea
Other Olea range products



P.66-67

P.66-67

P.66-67

P.66-67

P.142

P.142

P.108-109

P.108-109

P.191

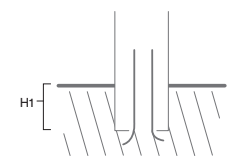
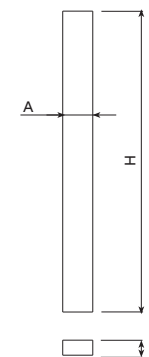

Ref.	A	B	H	H1
H318	100 mm	50 mm	1000 mm	-

*Opcional | En Option | Optional

Tic & Rom

Resistencia a la intemperie. Resistente a aceites, ácidos y agua de mar. No se degrada. No se astilla. Antigraffiti. Resistente a la humedad, no absorbe agua, de secado rápido. ECOLÓGICO proviene de producto reciclado y a la vez es reciclable. Larga vida útil. 100% Reciclable. Sin contaminantes. Fabricado de plásticos reciclados de alta calidad.

PREMIADO CON “DER BLAUE ENGEL” Producto con baja incidencia ambiental durante su ciclo de vida.

Résistant aux intempéries. Résistant aux huiles, acides et eau de mer. Ne se dégrade pas. Anti-graffiti. Résistant aux humidité, n'absorbe pas l'eau, sèche rapidement. ECOLOGIQUE, provient de matière recyclée et est également recyclable. Longue vie utile. 100% Recyclable. Sans contaminants. Fabriqué à partir de plastiques recyclés de haute qualité.

PRIX “DER BLAUE ENGEL”. Produit à faible impact environnemental durant son cycle de vie.

Weather resistant. Oil, acid & seawater resistant. It does not degrade. It doesn't splinter. Anti-graffiti. High resistance to hard weather conditions, no water absorption & fast drying. ENVIRONMENTALLY FRIENDLY, it comes from recycled material and is recyclable too. Long lifespan. 100% Recyclable. No pollutants. Made of high quality recycled plastic.

Awarded “DER BLAUE ENGEL” Product with low environmental impact during its life cycle.

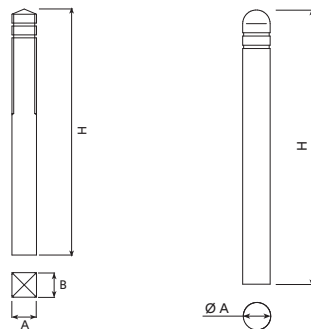

Ref.	A	B	H
H360	Ø 150 mm	-	1500 mm
H365	140 mm	140 mm	1400 mm

reBnew

Productos 100% plástico reciclado Rebnew
Produits 100% plastique recyclé Rebnew
Products 100% recycled plastic Rebnew



TIC
H360



ROM
H365



Otros productos ReBnew
Autres produits ReBnew
Other ReBnew range products



Hospitalet

Acero zincado con anillo de acero inoxidable. Imprimación epoxi y pintura poliéster en polvo color negro forja. Instalación: Base empotrable y varillas de rea con hormigón. Opcional: Con base extraíble (H214M/1C).

Acier zingúé avec un anneau en acier inoxydable. Couche primaire époxy et thermolaquage polyester noir de forge. Installation : Base à encastrer et tiges filetées avec béton. En option : avec base amovible (H214M/1C).

Made of metal and a stainless steel ring with epoxy primer coating and black wrought iron coloured polyester powder coated finish. Fitting: Embeddable base and bars with concrete. Optional: Removable (H214M/1C).



H214

H214-2

H214-4

H214PMR

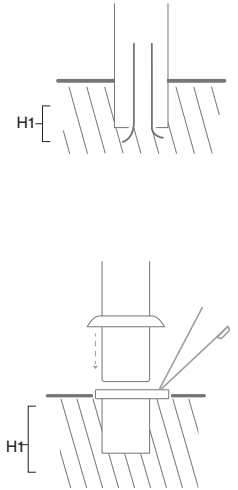
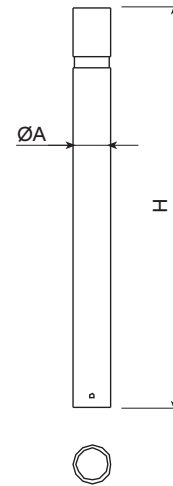

H214E/1C

H214P

H214PS



PL01



H214MB

Ref.	Ø A	B	H	H1
H214	95 mm	-	1000 mm	-
H214M/1C	95 mm	-	1005 mm	-
H214P	95 mm	-	810 mm	-
H214PS	95 mm	-	980 mm	185 mm
H214-2	95 mm	-	1200 mm	-
H214-4	95 mm	-	1400 mm	-
H214PMR	95 mm	-	1400 mm	-
H214E/1C	95 mm	120 mm	970 mm	170 mm

Hospitalet Flexible

Cauflex color negro, resistente al UV, con banda reflectante.
 Instalación: Base empotrable. Opcional: Con base empotrable extraíble (H214FCM).

Cauflex, couleur noire, résistant aux UV avec bande réfléchissante.
 Installation : base à encastrer. En option : avec base à encastrer amovible (H214FCM).

Black Cauflex coated, UV resistant with reflective band.
 Fitting: Embedded base. Optional: Embeddable, removable base (H214FCM).

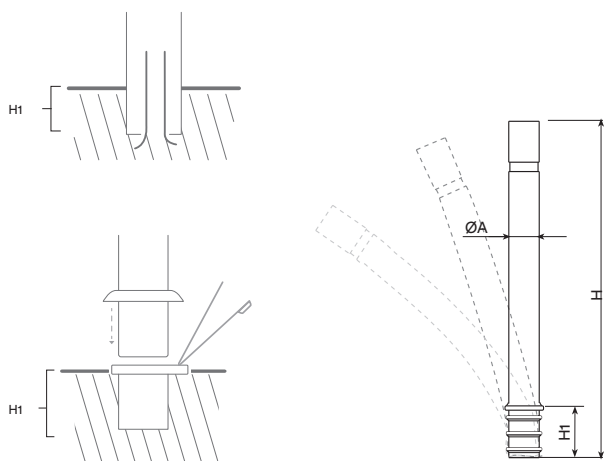
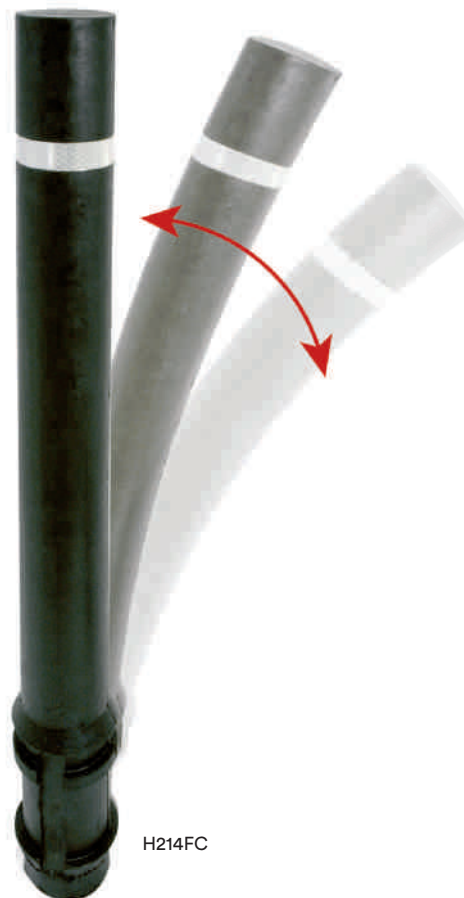

Ref.	Ø A	B	H	H1
H214FC	100 mm	-	990 mm	205 mm

*Opcional | En Option | Optional

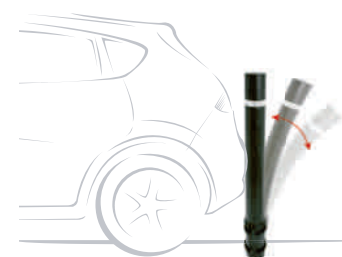

Anti-belier

Acero zincado con anillo de acero inoxidable. Imprimación epoxi y pintura poliéster en polvo color gris RAL 7016. Tapón extraíble para facilitar el relleno del hormigón en la pizona para una mejor resistencia. Instalación: Base empotrable y varillas de rea con hormigón.

Acier zingúé avec un anneau en acier inoxydable. Couche primaire époxy et thermolaquage polyester gris RAL 7016. Bouchon extractible afin de faciliter le remplissage de la borne avec du béton, pour obtenir une meilleure résistance. Installation : Base à encastrer et tiges filetées avec béton.

Made of metal and a stainless steel ring with epoxy primer coating and black wrought iron coloured polyester powder coated finish. Removable cap to ease the bollard concrete filling and achieve a better resistance. Fitting: Embeddable base and bars with concrete.



H268

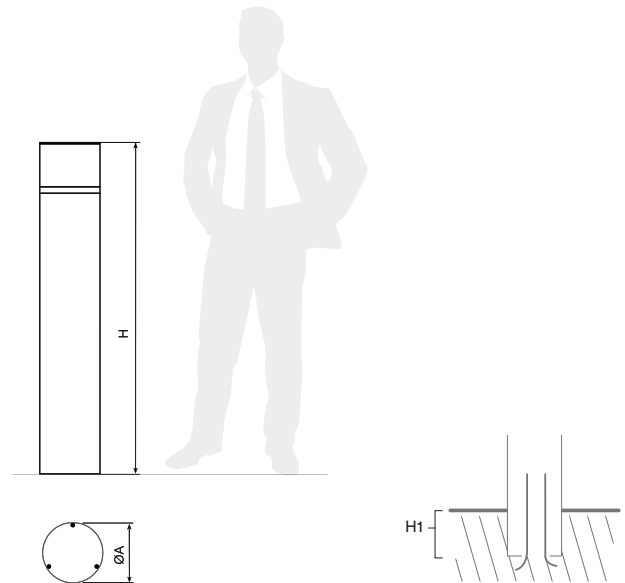

Ref.	Ø A	B	H	H1
H268	273 mm	-	1500 mm	500 mm

Kube

Hormigón prefabricado color gris granítico de aspecto liso. Se puede colocar en elementos aislados o en grupos.

Béton préfabriqué gris granite, aspect lisse. Peut être placé séparément ou en groupes.

Pre-cast smooth granite grey concrete. May be positioned individually or in groups.



H372

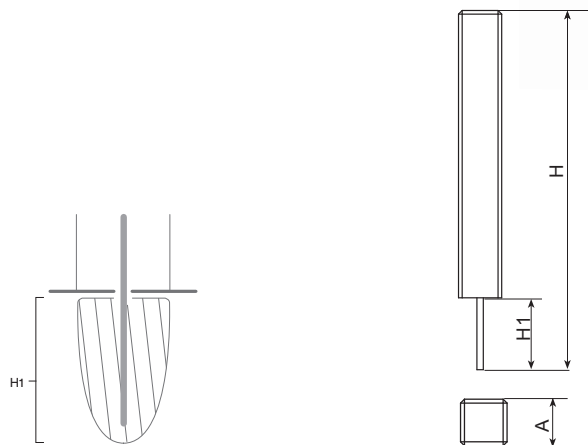

Ref.	A	B	H	H1
H372	120 mm	-	1000 mm	200 mm

Otros productos Kube
Autres produits Kube
Other Kube range products



P.40-41

P.44-45

P.44-45

P.38-39

P.44-45

P.44-45

P.38-39



P.40-41

P.40-41

P.102

P.102

P.151

P.151

P.196

Palamos

Pilona de madera tropical de sección 140 x 140 mm trata-
da con Lignus, protector fungicida, insecticida e hidrófugo.
Acabado color natural. También disponible en madera de
pino duo-trío con tratamiento autoclave a vacío-presión cla-
se 4 contra la carcoma, termitas e insectos. Instalación: base
empotrable. Opcional: Con base extraíble.

Bornes en bois tropical, section 140 x 140, traité au Lignus,
protection fongicide, insecticide et hydrofuge. Finition coloris
naturel. Également disponibles en pin duo-trío traité en auto-
clave sous vide et pression en classe 4 contre les vrillettes,
les termites et les insectes. Installation : base encastrable. En
option : à base amovible.

140 x 140 mm tropical wood posts, treated with Lignus, a
protective fungicide, insecticide and water proofing product.
Natural colour finish. Also available in duo-trío pine, vacu-
um-pressure treated in an autoclave to provide Class 4 protection
against woodworms, termites and other insects. Installation:
recessed base. Optional: removable base.



H250A



H250

Otros productos en madera de pino
Autres produits en pin
Other products made of pinewood



P.70-71



P.99



P.152-153



P.192



P.180-181



P.180-181



P.180-181



HL01N



H250M

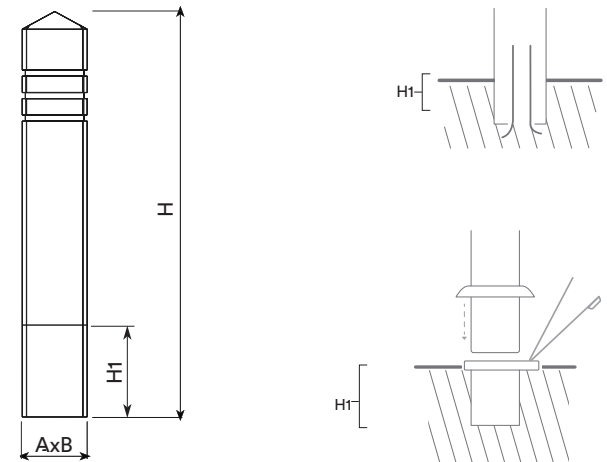

Ref.	A	B	H	H1
H250	140 mm	140 mm	1000 mm	200 mm
H250-2	140 mm	140 mm	1200 mm	200 mm
H250-4	140 mm	140 mm	1400 mm	200 mm
H250M/1	140 mm	140 mm	1000 mm	200 mm
H250-2M/1	140 mm	140 mm	1200 mm	200 mm
H250-4M/1	140 mm	140 mm	1400 mm	200 mm



Via trajana

By BENITO © ©

Acero zincado con imprimación epoxi y pintura poliéster en polvo color negro forja. Instalación: Base empotrable y varillas con hormigón. Opcional: Con base extraíble (H202MH/1C).

Acier zingué avec couche primaire époxy et thermolaquage polyester noir de forge. Installation : Base à encastrer et tiges filetées avec béton. En option: avec base amovible (H202MH/1C).

Galvanised steel with epoxy primer coating and black wrought iron coloured polyester powder coated finish. Fitting: Embeddable base and bars with concrete. Optional: Removable base (H202MH/1C).



H202H

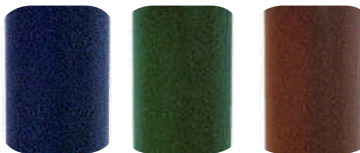

HL01



H200B

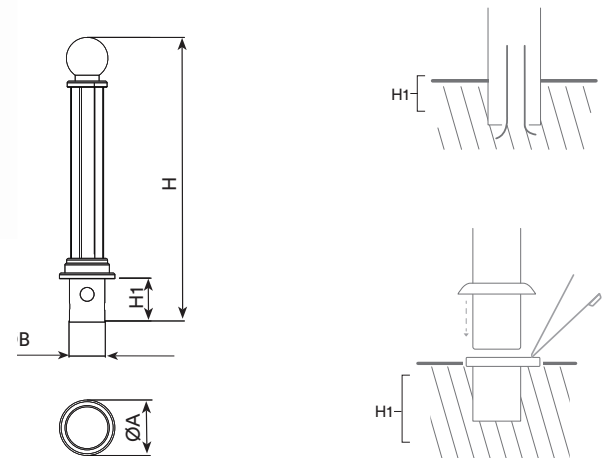

Ref.	Ø A	B	H	H1
H202H	160 mm	102 mm	820 mm	125 mm
H202MH/1C	160 mm	114 mm	825 mm	130 mm

Universal

Acero zincado con imprimación epoxi y pintura poliéster en polvo color negro forja. Instalación: Mediante 3 tornillos de anclaje Dynabolts.

Acier zingué avec couche primaire époxy et thermolaquage polyester noir de forge. Installation : par 3 chevilles d'ancrage Dynabolt.

Galvanised steel with epoxy primer coating and black wrought iron coloured polyester powder coated finish. Fitting: 3 Dynabolt anchors.



H211AP

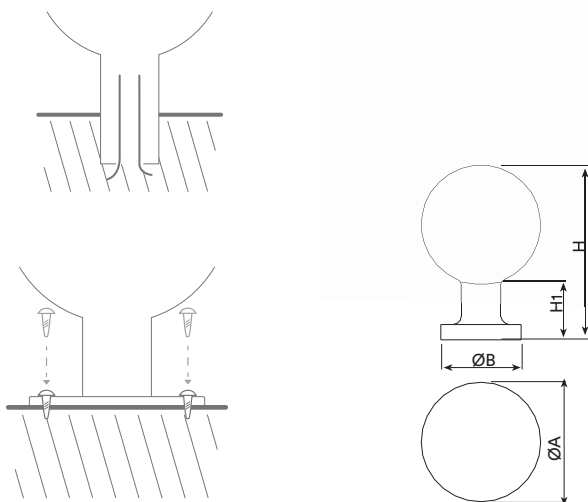

Ref.	Ø A	Ø B	H	H1
H211AP	300 mm	200 mm	410 mm	-

Desmontable

Acero zincado con imprimación epoxi y pintura poliéster en polvo color rojo y blanco reflectante. Base de acero galvanizado. Instalación: Base empotrable extraíble.

Acier zingué avec couche primaire époxy et thermolaquage polyester rouge et blanc réfléchissant. Fourreau en acier galvanisé. Installation: Fourreau à sceller.

Zinc-coated steel with epoxy primer coating and reflective white and red powder coating finish. Base made of galvanised steel. Fitting: Embedded removable base.

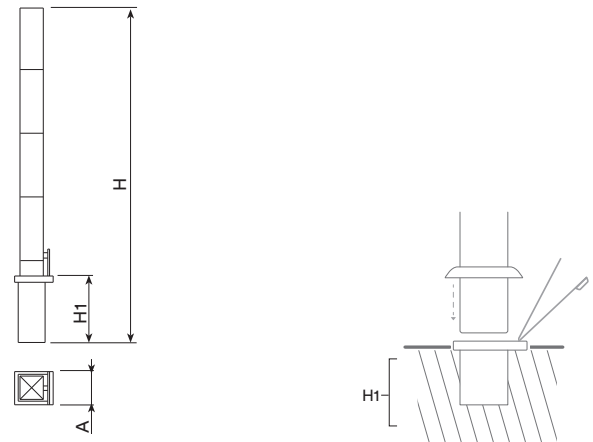
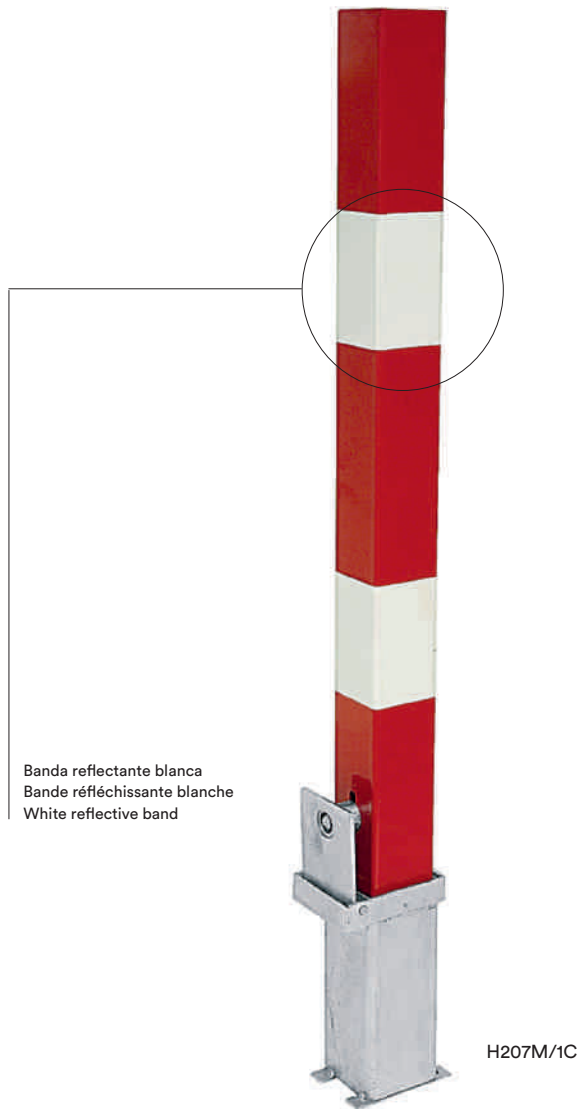

Ref.	A	B	H	H1
H207M/1C	70 mm	-	990 mm	210 mm



Kroc

Tubo de acero galvanizado. Acabado imprimación epoxi y pintura poliéster en polvo color amarillo RAL 1021. Instalación: Base empotrable.

Tube en acier galvanisé. Finition couche primaire époxy et thermolaquage polyester de couleur jaune RAL 1021. Installation : base à encastrer.

Galvanised steel tube with epoxy primer coating and yellow RAL 1021 polyester powder coated finish. Fitting: Embeddable base.

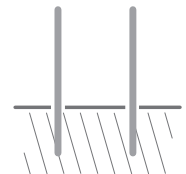
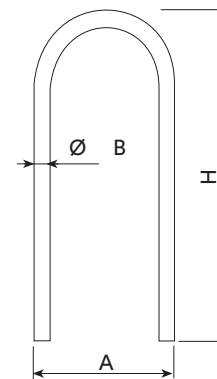

Ref.	A	B	H	H1
H292	345 mm	-	940 mm	-

Parking

Cuerpo de acero zincado con imprimación epoxi y pintura poliéster en polvo color amarillo RAL 1021. Con sistema abatible. Instalación: Mediante tres pernos de expansión.

Corps en acier zingué avec couche primaire époxy et thermo-laquage polyester de couleur jaune RAL 1021. Système rabattable. Installation : par 3 boulons à expansion.

Zinc-coated steel body with epoxy primer coating and yellow RAL 1021 polyester powder coated finish. Hinged system. Fitting: 3 expansion bolts.



H290

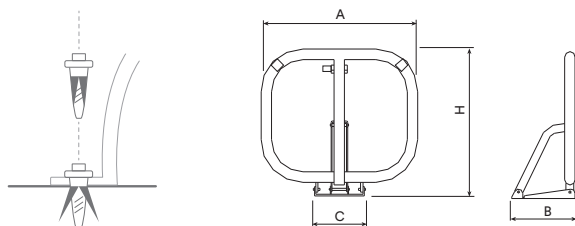

Ref.	A	B	C	H	H1
H290	610 mm	250 mm	194 mm	545 mm	-

Sol



H307-2

H307-2M/1

H307-4

H307-PMR

Acero con cataforesi, imprimación epoxi y pintura poliéster en polvo color gris RAL 7016. Instalación: Base empotrable y varilla corrugada. Opcional: Base empotrable (H307-2M/1).

Acier avec cataphorèse, couche primaire époxy et thermolaquage polyester gris RAL 7016. Installation : base à encastrer et tige filetée. En option : base à encastrer (H307-2M/1).

Steel with electrophoresis, epoxy primer coating and grey RAL 7016 polyester powder coated finish. Fitting: Embeddable base and rebar. Optional: Embeddable base (H307-2M/1).

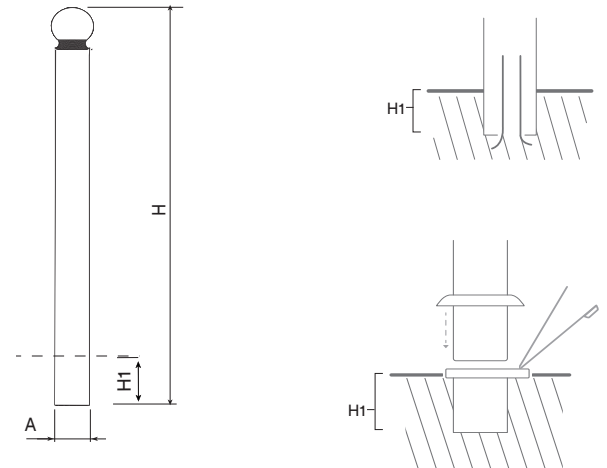

Ref.	Ø A	B	H	H1
H307-2	76 mm	-	1200 mm	200 mm
H307-2M/1	76 mm	-	1216 mm	180 mm
H307PMR	76 mm	-	1400 mm	200 mm
H307-4	76 mm	-	1400 mm	200 mm

Grey

Vigueta de acero Grey-100 zincada con imprimación epoxi y pintada en poliéster al horno color negro. Instalación: Base empotrable. Opcional: Con base extraíble (H221M/1).

Poutrelle en acier Grey-100 zingué avec couche primaire epoxy et peinture polyester au four, de couleur noire. Installation : Base à encastrer. En option : Avec base amovible (H221M/1).

Grey-100 zinc-coated steel joist with epoxy primer and black polyester coating (oven technique). Fitting: Embeddable base. Optional: Removable base (H221M/1).

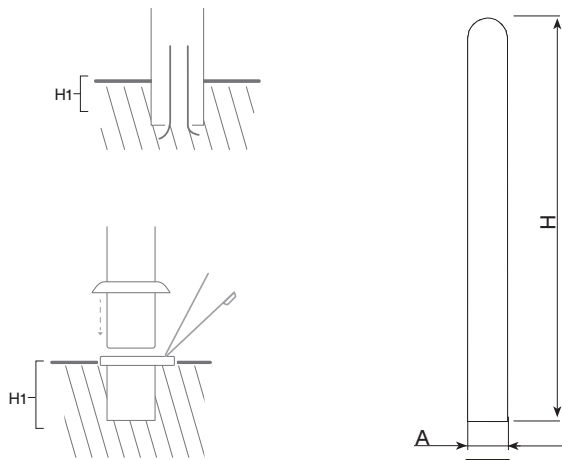

Ref.	A	B	H	H1
H221	100 mm	-	1000 mm	-
H221M/1	100 mm	-	1005 mm	210 mm



HL01N



H221B



H221



H2531
H2531M/1



H2531-2



H2571-4



H2571PMR



H2541



HL01N



H251B

Inox

Acero inoxidable AISI-304 pulido brillante. Instalación: Base empotrable y varillas corrugadas. Opcional: Con base extraíble (H2531M/1).

Acier inoxydable AISI-304 poli brillant. Installation : base à encastrer et tiges filetées. En option : avec base amovible (H2531M/1).

Shiny, polished stainless steel AISI-304. Fitting: Embeddable base and corrugated ribs. Optional: Removable base (H2531M/1).

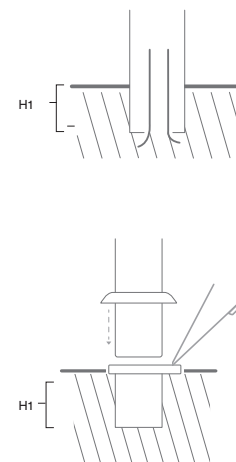
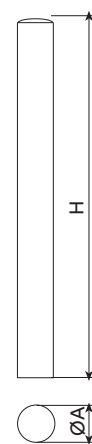

Ref.	A	B	H	H1
H2531-2	Ø90 mm	-	1200 mm	200 mm
H2571-4	Ø76 mm	-	1400 mm	200mm
H2571PMR	Ø76 mm	-	1400 mm	200 mm
H2541	Ø154 mm	-	700 mm	200 mm
H2531	90 mm	-	1000 mm	-
H2531M/1	90 mm	-	1005 mm	150 mm

Retractable

Pilona y chasis completo en acero inoxidable AISI-304 pulido brillante. Pilona retráctil (con base empotrada) con elevación automática y descenso manual. Instalación: Imprescindible hacer drenaje, para garantizar la evacuación del agua (ver instrucciones aparte).

Borne et châssis complets en acier inoxydable AISI-304 poli brillant. Borne rétractable (avec base à encastrer) avec montée automatique et abaissement manuel. Installation : Drainage indispensable pour garantir l'évacuation de l'eau (voir instructions à part).

Shiny, polished AISI-304 stainless steel bollard and chassis. Retractable bollard (embedded base) with automatic raising and manual lowering. Fitting: The soil should be well-drained to prevent the accumulation of water (see instructions).

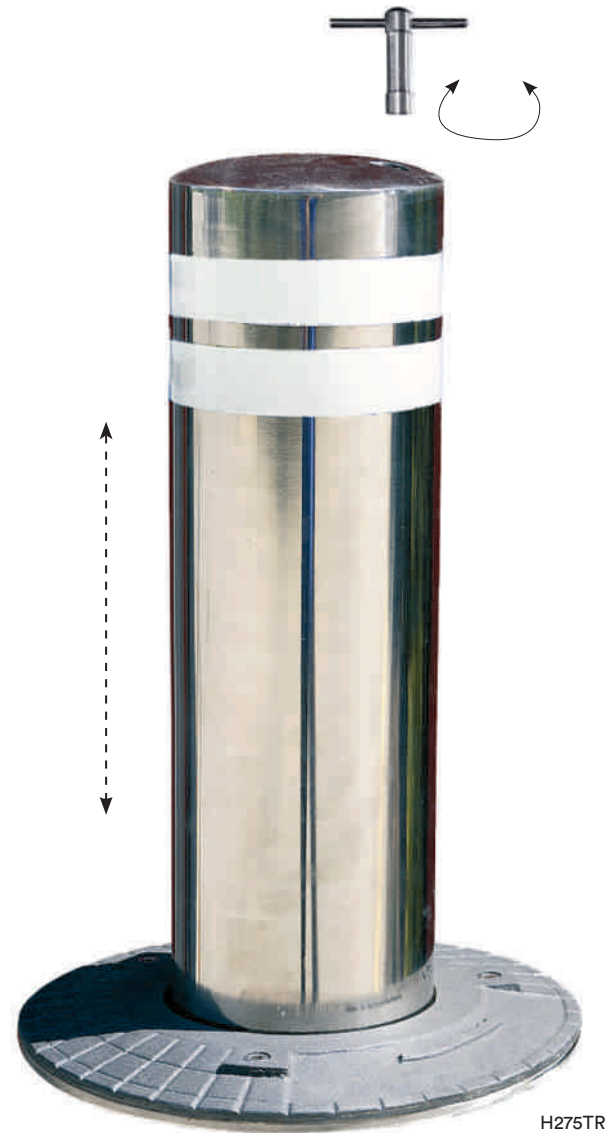
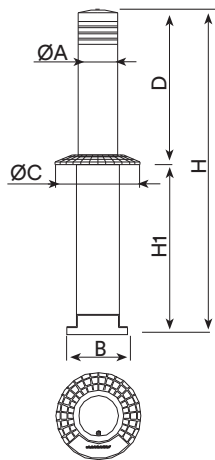

H275TR

Ref.	Ø A	B	C	D	H	H1
H275TR	140 mm	220 mm	300 mm	500 mm	1265 mm	745 mm

Automatic



H275AHG

Émbolo de acero inoxidable AISI-304 brillante de Ø270 x 600 mm de altura. Tapa superficial, chasis, sujeciones y tornillería en acero inoxidable. Señalización formada por 4 leds rojos y una banda reflectante blanca en la parte superior. Incluye 2 bucles de seguridad y mando a distancia. Cuadro de control: Cuadro eléctrico de poliamida color gris 500 x 400 mm por 230 mm de hondo. Con estanqueidad IP65 y cierre con llave especial. Protección eléctrica de seguridad mediante un diferencial. Automata para la gestión de las funcionalidades de la pizona, 2 detectores de seguridad y presencia + lazo de 2m x 2m y 15m de manguera para el conexionado. Receptor de 500 usuarios + un mando emisor, relés para la conexión de semáforos (verde i rojo). En el cuadro viene incorporado un programador horario semanal + la maniobra para la utilización de semáforo. Funcionamiento: Bajada con el mando a distancia y subida automática al paso del vehículo en un o dos sentidos de la marcha. Opcional: 1. Posibilidad de incorporar marcas personalizadas en la tapa de la pizona. 2. Sistema con semáforos con LEDS indicador de maniobra (color verde y rojo) 3. Sistema con lector de tarjetas HPLEP.

Borne rétractable télécommandée en acier inoxydable poli brillant Ø 270 mm, hauteur 600 mm. Couvercle superficiel, châssis et vis en acier inoxydable. Signalisation par 4 LED rouges et une bande réfléchissante blanche dans la partie supérieure. Comprend 2 boucles de sécurité et télécommande (2 m x 2 m). Panneau de contrôle : tableau électrique gris en polyamide 500 x 400 mm par 230 mm de profondeur. Étanchéité IP65 et fermeture avec clé spéciale. Protection électrique par différentiel. Automate de gestion des fonctionnalités de la borne, 2 détecteurs de sécurité et de présence + boucle de 2 m x 2 m et 15 m pour le câblage. Reconnaissance de 500 utilisateurs + une télécommande émetteur, relais de sortie pour le raccordement aux feux (vert et rouge). Le tableau comprend une programmation horaire hebdomadaire + la manœuvre pour l'utilisation de feux de signalisation. Fonctionnement : abaissement par télécommande et remontée automatique lors du passage d'un véhicule dans un sens ou dans les deux sens de circulation. En option : 1. Personnalisation du marquage de la borne. En option : personnalisation du marquage du couvercle de la borne. 2. Système avec feux à LED indicateur de manœuvre (vert et rouge) 3. Système de lecteur de cartes HPLEP.

Ø270 mm x 600 mm (h) AISI-304 stainless steel piston. Surface cover, chassis, fixings and bolts in stainless steel. Signalling consists of 4 red LEDs and a white reflective band on top. It features two security loop systems and a remote control. Control panel: 500 x 400 x 230 mm grey polyamide electrical panel. IP65 waterproofing and special locking key. Circuit breaker for electrical safety. Automaton for bollard functionality management. 2 automatic movement security detectors + 2m x 2m cable for connection. Receiver for up to 500 users + emitting controller and relays for traffic light connection (green and red). The control panel comes with a weekly scheduling system + traffic lights programming system. Use: The remote control initiates the lowering and raises automatically once the vehicle has passed, in one or two directions. Optional: 1. We offer the possibility of supplying the bollard cover with customised markings (upon request). 2. LED traffic light system indicator (green and red) 3. HPLEP card reader system.

Opcional | En Option | Optional

HPS1: Semáforo para la circulación de tráfico de un solo sentido.

Semáforo de acero inoxidable monobloque de 1,2 m de altura para control de acceso. Integra 2 focos LED de diámetro 100 mm y alta luminosidad de colores rojo-verde. Fijación: mediante 4 pernos.

HPS2: Semáforo para la circulación de tráfico de doble sentido.

Semáforo de acero inoxidable doble monobloque de 1,2 m de altura para control de acceso. Integra 4 focos LED de diámetro 100 mm y alta luminosidad (2 por cada lado) de colores rojo-verde. Fijación: mediante 4 pernos.

HPLEP: Sistema con lector de tarjetas

HPS1: Feu de signalisation pour la circulation à sens unique.

Feu de signalisation en acier inoxydable monobloc de 1,2 m de hauteur pour contrôle d'accès. Incorpore 2 spots LED de diamètre 100 mm et grande luminosité rouge-vert. Fixation: par 4 boulons.

HPS2: Feu de signalisation pour la circulation à double sens.

Feu de signalisation en acier inoxydable double monobloc de 1,2 m de hauteur pour contrôle d'accès. Incorpore 4 spots LED de diamètre 100 mm et grande luminosité (2 de chaque côté) rouges - verts. Fixation: par 4 boulons.

HPLEP: Système avec lecteur de cartes

HPS1: traffic lights designed for one way traffic.

1.2 m stainless steel standalone traffic lights to handle access control. It comes with 2 high luminosity LED lamps with a 100mm diameter and red-green colours. Ground installation: 4 fixing bolts.

HPS2: Traffic lights designed for two ways traffic.

It comes with 4 high luminosity LED lamps with a 100mm diameter (2 per side) and red-green colours. Ground installation: 4 fixing bolts.

HPLEP: Card reader system.





Acero corten | Acier corten | Corten steel

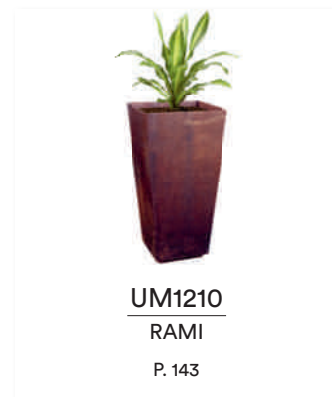
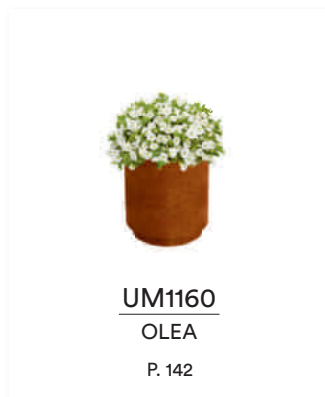
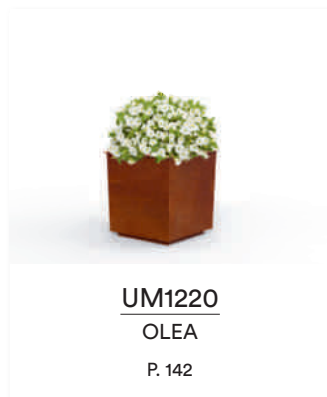

Acero | Acier | Steel

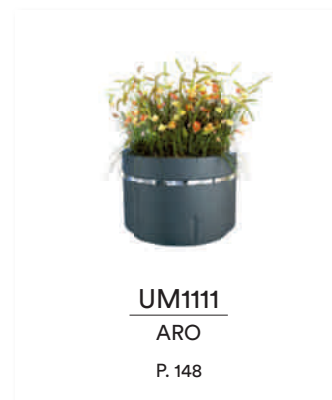
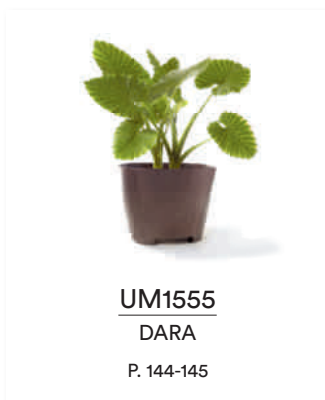

reBnew

Hormigón | Betón prefabricado | Concrete

Madera | Bois | Wood

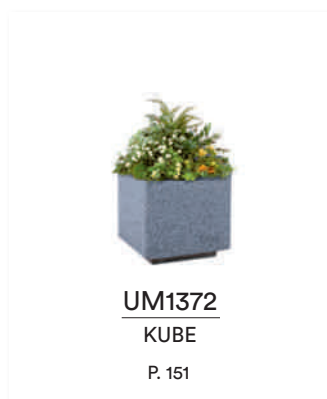

Ner

Jardinera de chapa de Acero Corten, concebida para permanecer en el tiempo sin ningún tipo de mantenimiento. No necesita ningún acabado, evita procesos contaminantes y contribuye a la sostenibilidad medioambiental.

Nota: La oxidación del acero corten evoluciona con el paso del tiempo y se oxida, más o menos rápido, en función de la temperatura ambiente y la humedad. P. 08

Jardinière en tôle d'acier Corten, conçue pour durer très longtemps sans aucun type d'entretien. Ne requérant aucune finition, elle permet d'éviter les processus polluants en contribuant ainsi à la durabilité de l'environnement.

Note : L'oxydation de l'acier évoluera au fil du temps, et sera plus ou moins rapide en fonction de la température ambiante et de l'humidité. P. 08

Planter made from Corten steel plate, designed to last maintenance-free over time. Needs no finish, which eliminates processes that pollute the environment, contributing to sustainability.

Note: the rustiness from Corten steel evolves overtime, which means that this material sooner or later will get rusty depending on the humidity and temperature levels. P. 08



UM1200

UM1202

UM1204

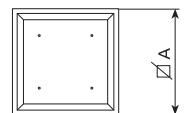
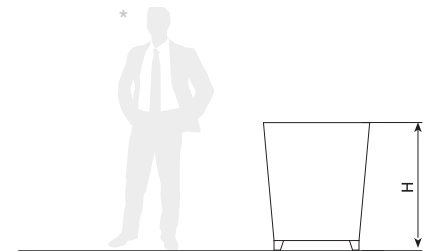

Ref.	A	B	H
* UM1200	1000 mm	1000 mm	1200 mm
UM1202	720 mm	720 mm	1000 mm
UM1204	600 mm	600 mm	780 mm





* Acabado imprimación epoxi y pintura poliéster en polvo color MARSON.

* Finition couche primaire époxy et thermolaquage polyester teinte MARSON.

* Epoxy primer coating and MARSON polyester powder coated finish.

UM1160



UM1220

Olea

Jardinera de chapa de Acero Corten, concebida para permanecer en el tiempo sin ningún tipo de mantenimiento. No necesita ningún acabado, evita procesos contaminantes y contribuye a la sostenibilidad medioambiental.

Nota: La oxidación del acero corten evoluciona con el paso del tiempo y se oxida, más o menos rapido, en función de la temperatura ambiente y la humedad. P. 08

Jardinière en tôle d'acier Corten, conçue pour durer très longtemps sans aucun type d'entretien. Ne requérant aucune finition, elle permet d'éviter les processus polluants en contribuant ainsi à la durabilité de l'environnement.

Note: L'oxydation de l'acier évoluera au fil du temps, et sera plus ou moins rapide en fonction de la température ambiante et de l'humidité. P. 08

Planter made from Corten steel plate, designed to last maintenance-free over time. Needs no finish, which eliminates processes that pollute the environment, contributing to sustainability.

Note: the rustiness from Corten steel evolves overtime, which means that this material sooner or later will get rusty depending on the humidity and temperature levels. P. 08

Otros productos Olea
Autres produits Olea
Other Olea range products



P:108-109 P:108-109 P:118



P:66-67 P:66-67 P:66-67 P:66-67 P:191

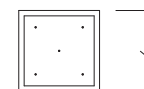
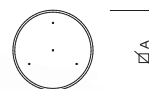
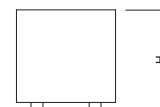
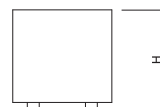

Ref.	A	B	H
UM1160 \emptyset	750 mm	750 mm	750 mm
UM1220 \square	750 mm	750 mm	750 mm

*Opcional | En Option | Optional

Rami

Jardinera de chapa de Acero Corten, concebida para permanecer en el tiempo sin ningún tipo de mantenimiento. No necesita ningún acabado, evita procesos contaminantes y contribuye a la sostenibilidad medioambiental.

Nota: La oxidación del acero corten evoluciona con el paso del tiempo y se oxida, más o menos rápido, en función de la temperatura ambiente y la humedad. P. 08

Jardinière en tôle d'acier Corten, conçue pour durer très longtemps sans aucun type d'entretien. Ne requérant aucune finition, elle permet d'éviter les processus polluants en contribuant ainsi à la durabilité de l'environnement.

Note: L'oxydation de l'acier évoluera au fil du temps, et sera plus ou moins rapide en fonction de la température ambiante et de l'humidité. P. 08

Planter made from Corten steel plate, designed to last maintenance-free over time. Needs no finish, which eliminates processes that pollute the environment, contributing to sustainability.

Note: the rustiness from Corten steel evolves overtime, which means that this material sooner or later will get rusty depending on the humidity and temperature levels. P. 08

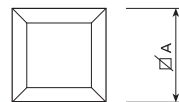
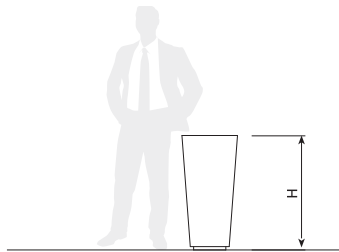

Ref.	A	B	H
UM1210	500 mm	500 mm	1030 mm

UM1210



UM1555

Dara

By BENITO © ©

Acero con tratamiento Ferrus, proceso protector del hierro, que garantiza una óptima resistencia a la corrosión. Acabado zincado electrolítico con imprimación epoxi y pintura poliéster en polvo color marrón RAL 8019.

Acier avec traitement Ferrus, procédé qui protège le fer et garantit une résistance optimale à la corrosion. Finition zingage électrolytique et thermolaquage polyester marron RAL 8019.

Steel treated with Ferrus, a protective process that guarantees high corrosion resistance. Electro-galvanised finish with epoxy primer coating and brown RAL 8019 polyester powder coated finish.

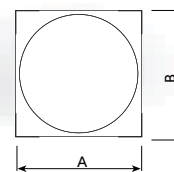
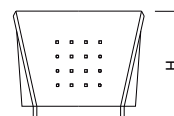

Ref.	A	B	H
UM1555	745 mm	745 mm	500 mm





UM1100PM



UM1100M

Esferica

By Bach y Mora © © BENITO

Acero con tratamiento Ferrus, proceso protector del hierro, que garantiza una óptima resistencia a la corrosión. Acabado zincado electrolítico con imprimación epoxi y pintura poliéster en polvo color negro forja. Anclaje recomendado: Tornillos de fijación al suelo de M10 según superficie y proyecto.

Acier avec traitement Ferrus, procédé qui protège le fer et garantit une résistance optimale à la corrosion. Finition zingage électrolytique et thermolaquage polyester noir de forge. Ancrage recommandé : vis M10 pour la fixation au sol, en fonction de la surface et du projet.

Steel treated with Ferrus, a protective process that guarantees high corrosion resistance. Electro-galvanised finish with epoxy primer coating and black wrought iron coloured polyester powder coated finish. Recommended anchoring: M10 bolts to anchor to the ground, depending on the surface and the project.

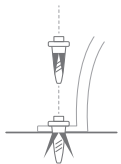
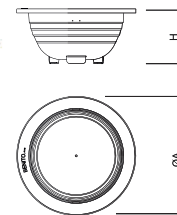

Ref.	A	H
UM1100PM	930 mm	405 mm
UM1100M	1300 mm	470 mm



Aro

By BENITO ©

Acero con tratamiento Ferrus, proceso protector del hierro, que garantiza una óptima resistencia a la corrosión. Acabado zincado electrolítico con imprimación epoxi y pintura poliéster en polvo color negro forja. Anillo de acero inoxidable.

Acier avec traitement Ferrus, procédé qui protège le fer et garantit une résistance optimale à la corrosion. Finition zingage électrolytique et thermolaquage polyester noir de forge. Anneau en acier inoxydable.

Steel treated with Ferrus, a protective process that guarantees high corrosion resistance. Electro-galvanised finish with epoxy primer coating and black wrought iron coloured polyester powder coated finish. Stainless steel ring.



UM1111

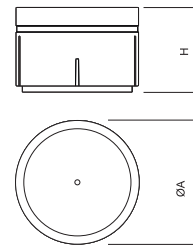

Ref.	A	H
UM1111	810 mm	560 mm

Rectangular

Acero con tratamiento Ferrus, proceso protector del hierro, que garantiza una óptima resistencia a la corrosión. Acabado zincado electrolítico con imprimación epoxi y pintura poliéster en polvo color negro forja. Anclaje recomendado: Tornillos de fijación al suelo de M10 según superficie y proyecto.

Acier avec traitement Ferrus, procédé qui protège le fer et garantit une résistance optimale à la corrosion. Finition zingage électrolytique et thermolaquage polyester noir de forge. Ancrage recommandé : vis M10 pour la fixation au sol, en fonction de la surface et du projet.

Steel treated with Ferrus, a protective process that guarantees high corrosion resistance. Electro-galvanised finish with epoxy primer coating and black wrought iron coloured polyester powder coated finish. Recommended anchoring: M10 bolts to anchor to the ground, depending on the surface and the project.



UM1152

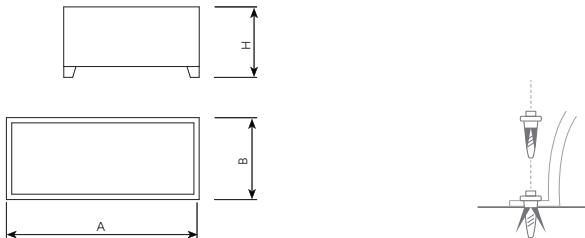

Ref.	A	B	H
UM1152	1000 mm	425 mm	520 mm

reBnew

Productos 100% plástico reciclado Rebnew
 Produits 100% plastique recyclé Rebnew
 Products 100% recycled plastic Rebnew



Otros productos ReBnew
 Autres produits ReBnew
 Other ReBnew range products



Gar

Resistencia a la intemperie. Resistente a aceites, ácidos y agua de mar. No se degrada. No se astilla. Antigraffiti. Resistente a la humedad, no absorbe agua, de secado rápido. ECOLÓGICO proviene de producto reciclado y a la vez es reciclable. Larga vida útil. 100% Reciclable. Sin contaminantes. Fabricado de plásticos reciclados de alta calidad.

PREMIADO CON “DER BLAUE ENGEL” Producto con baja incidencia ambiental durante su ciclo de vida.

Résistant aux intempéries. Résistant aux huiles, acides et eau de mer. Ne se dégrade pas. Anti-graffiti. Résistant aux humidité, n'absorbe pas l'eau, sèche rapidement. ECOLOGIQUE, provient de matière recyclée et est également recyclable. Longue vie utile. 100% Recyclable. Sans contaminants. Fabriqué à partir de plastiques recyclés de haute qualité.

PRIX “DER BLAUE ENGEL”. Produit à faible impact environnemental durant son cycle de vie.

Weather resistant. Oil, acid & seawater resistant. It does not degrade. It doesn't splinter. Anti-graffiti. High resistance to hard weather conditions, no water absorption & fast drying. ENVIRONMENTALLY FRIENDLY, it comes from recycled material and is recyclable too. Long lifespan. 100% Recyclable. No pollutants. Made of high quality recycled plastic.

Awarded “DER BLAUE ENGEL” Product with low environmental impact during its life cycle.

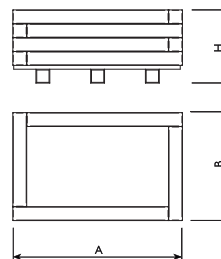

Ref.	A	B	H
UM1480	1100 mm	700 mm	475 mm

Kube

Hormigón prefabricado color gris granítico de aspecto liso. Se puede colocar en elementos aislados o en grupos. Anclaje recomendado: Apoyado por su propio peso.

Béton préfabriqué gris granite, aspect lisse. Peut être placé séparément ou en groupes. Ancrage recommandé : posé à terre.

Pre-cast smooth granite grey concrete. May be positioned individually or in groups. Recommended anchoring: free-standing.



UM1373



UM1372

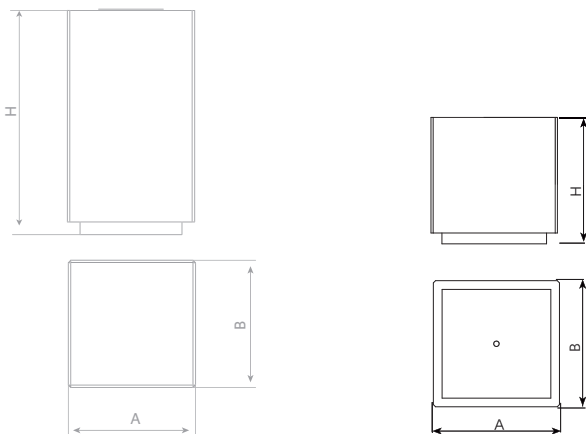

Ref.	A	B	H
UM1372	500 mm	500 mm	580 mm
UM1373	500 mm	500 mm	980 mm

Otros productos Kube
Autres produits Kube
Other Kube range products

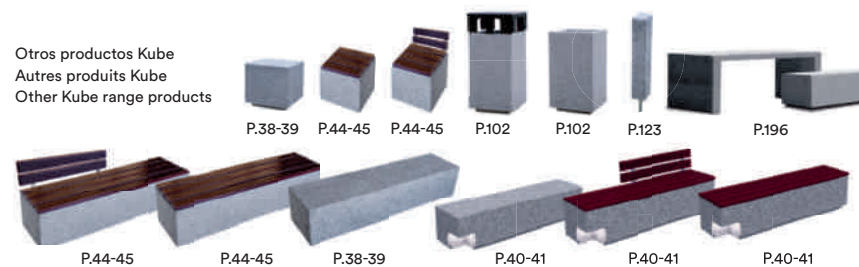

Madera



UM1640-6



UM1640-5



UM1640-2



UM1640-1



UM1640-4

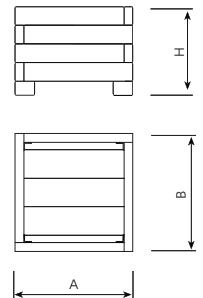

Tablones de madera de pino con tratamiento autoclave a vacío-presión clase 4 contra la carcoma, termitas e insectos. Jardinera apoyada sobre cuatro soportes de madera.

Sabías que... la madera natural "respira" es decir, absorbe y desprende la humedad en ambiente seco. Por lo tanto, es normal que puedan aparecer grietas en la madera. No influencia para nada en su capacidad de resistencia y su durabilidad. P. 10

Lames de bois de pin avec traitement autoclave à pression à vide, classe 4, contre la vermoulure, les termites et les insectes. La jardinière a quatre supports d'appui en bois.

Saviez vous que... le bois naturel "respire", c'est-à-dire, qu'il absorbe et restitue de l'humidité dans une atmosphère sèche. Il est par conséquent normal que des fissures apparaissent dans le bois. Ceci n'influence en rien sa capacité de résistance et sa durabilité. P. 10

Made of pine wooden boards autoclave vacuum-pressure treated against woodworm, termite and insect. 4 Class. It is fitted with four wooden stands.

Did you know... natural wood "breathes" i.e. it absorbs humidity and releases it in dry atmospheres. It is therefore normal for cracks to appear in wood. This has no effect whatsoever on its strength and durability. P. 10

Otros productos en madera de pino
Autres produits en bois de pin
Other products made of pinewood



P.70-71



P.124-125

P.99



P.246



P.180-181

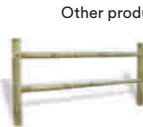

P.180-181



P.180-181

Ref.	A	B	H
UM1640/1	1800 mm	600 mm	450 mm
UM1640/2	1000 mm	500 mm	450 mm
UM1640/4	1000 mm	1000 mm	655 mm
UM1640/5	600 mm	600 mm	450 mm
UM1640/6	1000 mm	1000 mm	1000 mm





Acero | Acier | Steel



UM551
TERRIER
P. 158



UM550
HUSKY
P. 158



UM511/1M
ATLAS
P. 159



UM511/2M
ATLAS
P. 159



UM510/1M
EGEA
P. 160

Fundición | Fonte | Cast iron



UM502
BARCINO
P. 161



UM508
FONTI
P. 163

Hormigón | Betón prefabricado | Concrete



UM509
FONTI
P. 163

Acero inoxidable | Acier inoxydable | Stainell steel



UM540
DUAL
P. 156



UM508I
INOX
P. 162

Dual



Columna triangular y salpicaderos en inoxidable brillante y satinado. Embellecedores acabados pintura poliéster en polvo color rojo cobre. Grifería ergonómica. Anclaje recomendado: Atornillada mediante 3 pernos de expansión M12.

Colonne triangulaire, robinetterie et réceptacle en acier inoxydable. Ornaments avec finition en peinture polyester en poudre coloris rouge cuivré. Robinetterie ergonomique. Ancrage recommandé : Par 3 boulons à expansion M12.

Triangular column and splash guard in shiny, glossy stainless steel. Trims powder coated in red copper polyester paint. Economical taps. Recommended anchoring: Three M12 expansion bolts.



UM540I

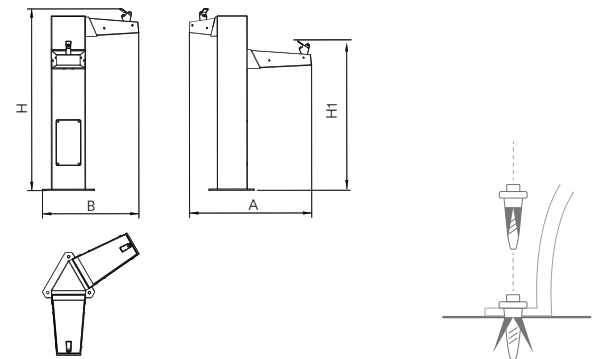

Ref.	A	B	H	H1
UM540I	700 mm	550 mm	1040 mm	855 mm





UM550

UM551

Husky



Fuente con 2 grifos pulsadores a dos alturas, uno adaptado para perros. Cuerpo de acero galvanizado acabado pintura poliéster en polvo color negro forja. Cubetas de acero inoxidable Aisi 304 acabado satinado.

Altura de la cubeta baja: 200 mm.

Altura de la cubeta alta : 980 mm

Fontaine avec deux robinets poussoir à deux hauteurs, dont une adaptée pour les chiens.

Corps en acier galvanisé finition peinture en poudre de couleur noir forge. Réceptacles en acier inoxydable AISI 304 finition satinée.

Hauteur du réceptacle inférieur : 200mm.

Hauteur du réceptacle supérieur : 980mm

This fountain features 2 pushing taps at different heights, one located at the lower part specially designed to be used by dogs. The body is made of galvanised steel with a black forge polyester powder coated finish and both trays consist of satin finish AISI 304 stainless steel.

Height of the lower tray: 200 mm

Height of the top tray: 980 mm

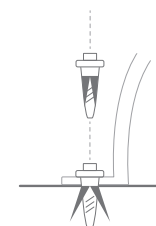
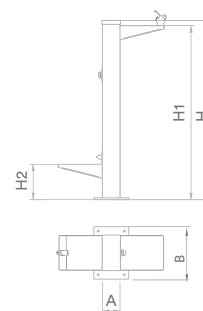

Ref.	A	B	H	H1	H2
UM550	100 mm	300 mm	1010 mm	980 mm	200 mm
UM551	100 mm	300 mm	1010 mm	-	200 mm



Atlas

By BENITO ©

Cuerpo cuadrado de hierro con tratamiento Ferrus, proceso protector del hierro que garantiza una óptima resistencia a la corrosión. Acabado imprimación epoxi y pintura poliéster en polvo color gris martelé. Pletina fijación-grifo pulsador de acero niquelado (UM510G). Reja sumidero de fundición dúctil y marco angular de acero acabado pintura poliéster al horno color negro forja.

Corps carré en fer traité avec Ferrus, un procédé qui protège le fer et garantit une résistance optimale à la corrosion. Finition couche primaire époxy et peinture poudre polyester de couleur gris martelé. Plat fixation-robinet poussoir en acier nickelé (UM510G). Grille avaloir en fonte ductile et cadre triangulaire en acier, finition thermolaquage polyester noir de forge.

Square iron body treated with Ferrus, a protective process for iron that guarantees high corrosion resistance. Epoxy primer and grey marteled polyester powder coated paint finish. Fixing bar-push button tap in nickel-plated steel (UM510G). Ductile cast iron drain grate and steel corner frame with oven-baked black wrought iron coloured polyester paint finish.

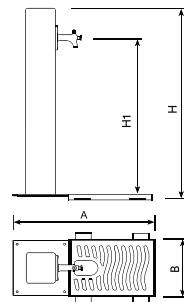
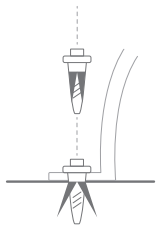

Ref.	A	B	H	H1
UM511/1M	-	300 mm	1010 mm	850 mm
UM511/2M	-	300 mm	1010 mm	850 mm



Egea

By Puig & Darnés © BENITO



UM510-1M

Cuerpo de acero de $\varnothing 190$ mm con tratamiento Ferrus, proceso protector del hierro, que garantiza una óptima resistencia a la corrosión. Acabado imprimación epoxi y pintura poliéster en polvo color verde RAL 6005. Base con soporte y reja sumidero de fundición dúctil. Grifo pulsador (UM510G) con soporte en acero niquelado.

Corps en acier de $\varnothing 190$ mm, traité avec Ferrus, procédé qui protège le fer et garantit une résistance optimale à la corrosion. Finition couche primaire époxy et peinture poudre polyester de couleur vert RAL 6005. Base avec support et grille avaloir en fonte ductile. Robinet poussoir (UM510G) avec support en acier nickelé.

$\varnothing 190$ mm steel body treated with Ferrus, a protective process for iron that guarantees high resistance to corrosion. Epoxy primer and green RAL 6005 polyester powder coated paint finish. Base with support and drain grate in ductile cast iron. Push button tap (UM510G) with nickel-plated steel support.

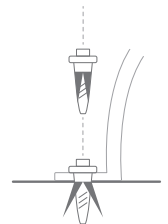
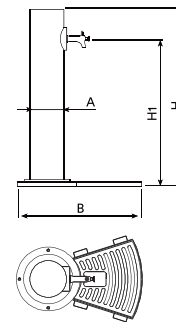

Ref.	A	B	H	H1
UM510/1M	$\varnothing 190$ mm	-	1030 mm	865 mm

Barcino

Fuente de fundición con imprimación epoxi y pintura de poliuretano color negro forja. Grifo pulsador de latón (UM502G). Anclaje recomendado: Mediante cuatro pernos de expansión de M14.

Fontaine en fonte avec couche primaire époxy et thermo-laquage polyester noir de forge. Robinet poussoir en laiton. (UM502G). Ancrage recommandé : Par quatre boulons à expansion M14.

Cast iron drinking fountain with primer coating and two coats of black wrought iron coloured paint. Brass push button tap (UM502G). Recommended anchoring: Four M14 expansion bolts.

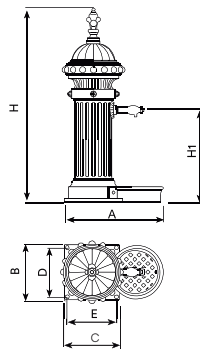
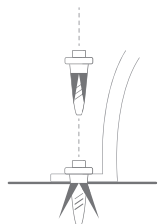

Ref.	A	B	C	D	E	H	H1
UM502/1	630 mm	395 mm	380 mm	330 mm	300 mm	1250 mm	550 mm



Inox

Acero inoxidable, acabado pulido brillante. Instalación: Mediante tres pernos de expansión de M8.

Acier inoxydable, finition poli brillant. Installation : par 3 boulons à expansion M8.

Shiny, polished stainless steel finish. Fitting: Three M8 expansion bolts.

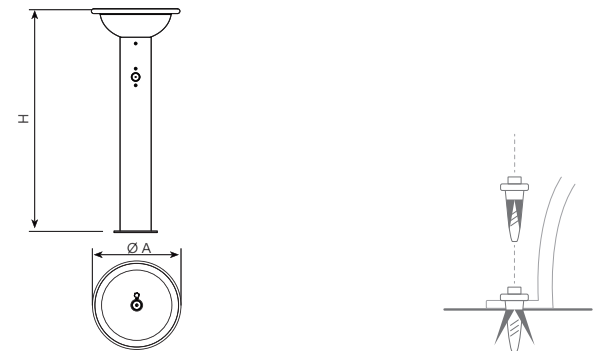

Ref.	A	B	H	H1
UM508I	$\varnothing 370$ mm	-	935 mm	-

Fonti

By BENITO ©

Fundición con imprimación epoxi y pintura al horno poliéster color negro forja. Instalación: Mediante tres pernos de expansión de M8.

Fonte avec couche primaire époxy et thermolaquage polyester noir de forge. Installation : Par 3 boulons à expansion M8.

Cast iron with primer coating and two coats of black wrought iron coloured paint finish. Fitting: Three M8 expansion bolts.

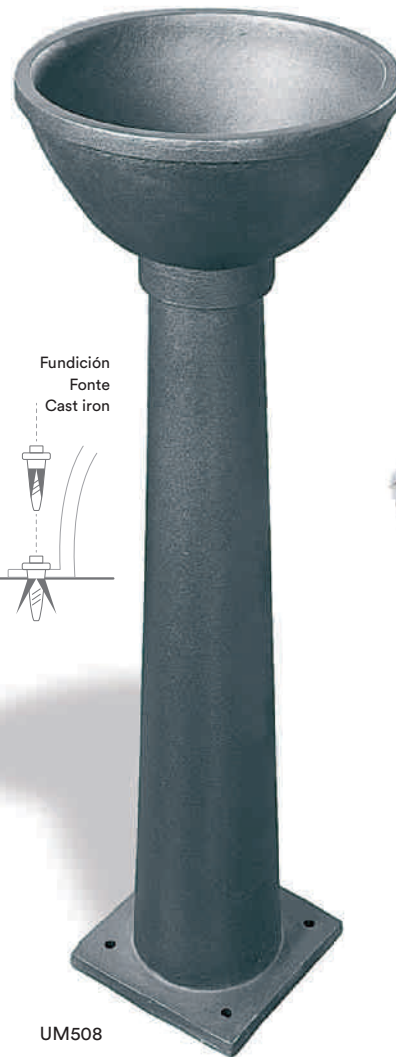
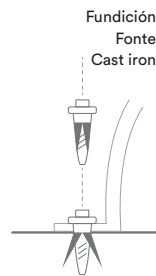

UM508

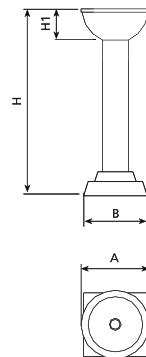

Hormgón*
Béton*
Concrete*



Ref.	A	B	H	H1
UM508	Ø310 mm	200 mm	985 mm	155 mm
UM509	310 mm	290 mm	850 mm	140 mm

*Opcional | En Option | Optional

UM508L
Pulsador lateral *
Poussoir *
Push *





Acero | Acier | Steel



A25A
TAULAT

P. 166-167

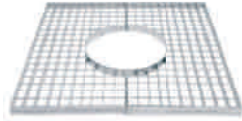

A80
REL

P. 170-171

Fundición | Fonte | Cast iron



A54N
BRICO

P. 168-169



Taulat

By Bernat Martorell Pena © BENITO

Acero galvanizado con tratamiento Ferrus, proceso protector del hierro, que garantiza una óptima resistencia a la corrosión. Acabado imprimación epoxi y pintura poliéster en polvo color negro forja. Aberturas circulares: 18mm. A25A con 3 aberturas circulares. A26A, A27A y A29A con 4 aberturas circulares. Se entrega en 2 piezas. Opcional: Marco angular de acero, L45.

Acier galvanisé avec traitement Ferrus, procédé qui protège le fer et garantit une résistance optimale à la corrosion. Finition couche primaire époxy et thermolaquage polyester noir de forge. Ouvertures circulaires : 18 mm. A25A avec 3 ouvertures circulaires. A26A, A27A et A29A avec 4 ouvertures circulaires. Livré en 2 pièces. En option : cadre angulaire en acier, L45.

Galvanised steel treated with Ferrus, a protective process for iron that guarantees high corrosion resistance. Epoxy primer coating and black wrought iron coloured polyester powder coated finish. Circular openings: 18 mm. A25A with 3 circular openings. A26A, A27A and A29A with 4 circular openings. Supplied in 2 parts. Optional: Angular metal frame, L45.

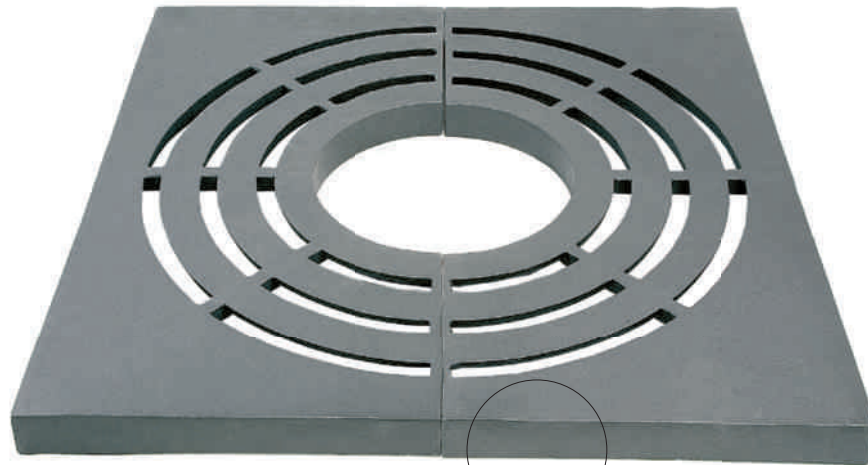

A25A

Marco angular de acero, L45*
Cadre angulaire en acier, L45*
Angular metal frame, L45*



Se adapta fácilmente a los diferentes diámetros de los árboles
S'adapte facilement aux différents diamètres des arbres
Easily adapted to different diameters of every tree perimeter

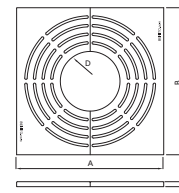
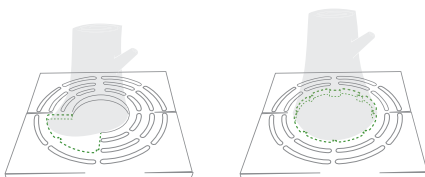

Ref.	A	B	H	Ø D
A25A	795 mm	795 mm	40 mm	Ø300 mm
A26A	995 mm	995 mm	40 mm	Ø300 mm
A27A	1195 mm	1195 mm	40 mm	Ø470 mm
A29A	1495 mm	1495 mm	40 mm	Ø500 mm

*Opcional | En Option | Optional





Brico

By Carles Casamor & Marta Gabàs © © BENITO



A55N



A56N



A57N

Fundición dúctil sin pintar (oxidado). Se entrega en 4 piezas. Anclaje recomendado: Auto-anclaje con tornillos y cimentación.

Nota: La oxidación del acero corten evoluciona con el paso del tiempo y se oxida, más o menos rápido, en función de la temperatura ambiente y la humedad. P. 08

Fonte ductile sans peinture (oxydé). Livré en 4 pièces. Ancre recommandé : Par auto-ancrage et cimentée.

Note: L'oxydation de l'acier évoluera au fil du temps, et sera plus ou moins rapide en fonction de la température ambiante et de l'humidité. P. 08

Ductile iron, unpainted (oxidated). Supplied in 4 parts. Recommended anchoring: Self-anchoring with bolts and concrete.

Note: the rustiness from Corten steel evolves overtime, which means that this material sooner or later will get rusty depending on the humidity and temperature levels. P. 08

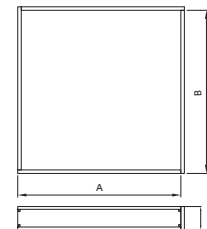

Ref.	A	B	H
A55N	1000 mm	1000 mm	200 mm
A56N	1200 mm	1200 mm	200 mm
A57N	1400 mm	1400 mm	200 mm



Rel

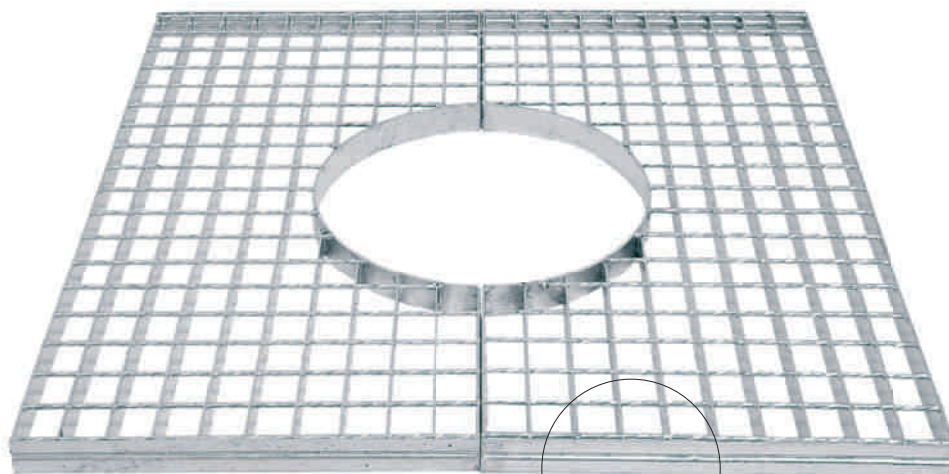

Marco angular de acero, L45*
Cadre angulaire en acier, L45*
Angular metal frame, L45*



Malla electrosoldada de 34 × 38mm, entre ejes, pletina portante de 30×2mm, separador cuadrado de 4mm entregirado . Acabado galvanizado en caliente. Diámetro interior de 300mm (Opcional otras medidas). Se entrega en 2 partes. Otras aplicaciones: En pasarelas, lucernarios, peldaños, vallas, etc. Opcional: Marco angular de acero galvanizado formado por cuatro partes, sin soldar (A80M, A81M, A82M, A83M, A84M, A85M, A86M, A87M).

Caillebotis électroforqué de 34 × 38mm, entraxes, plat porteur de 30 × 2mm, entretoise en carré torsadé. Finition : Galvanisation à chaud. Diamètre intérieur de 300 mm (Autres dimensions en option). Livré en 2 pièces. Autres applications : passerelles, verrières, marches, barrières, etc. En option : Cadre angulaire en acier (A80M, A81M, A82M, A83M, A84M, A85M, A86M, A87M).

Electro-welded mesh (34 × 38mm), between axes, suspension brace (30 × 2mm), 4mm-braid square divider. Finish: hot-dip galvanised. Inner diameter: Ø 300mm (other dimensions available upon request). Supplied in 2 parts. Other applications: Footbridges, skylights, rungs, fences, etc. Optional: Angular metal frame (A80M, A81M, A82M, A83M, A84M, A85M, A86M, A87M).

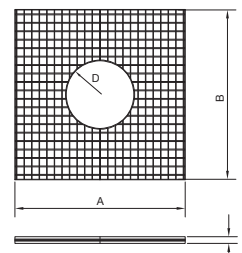

Ref.	A	B	H	Ø D
A80	490 mm	490 mm	30 mm	300 mm
A81	560 mm	560 mm	30 mm	300 mm
A82	695 mm	695 mm	30 mm	300 mm
A83	765 mm	765 mm	30 mm	300 mm
A84	900 mm	900 mm	30 mm	300 mm
A85	970 mm	970 mm	35 mm	300 mm
A86	1105 mm	1105 mm	35 mm	300 mm
A87	1175 mm	1175 mm	35 mm	300 mm

*Opcional | En Option | Optional

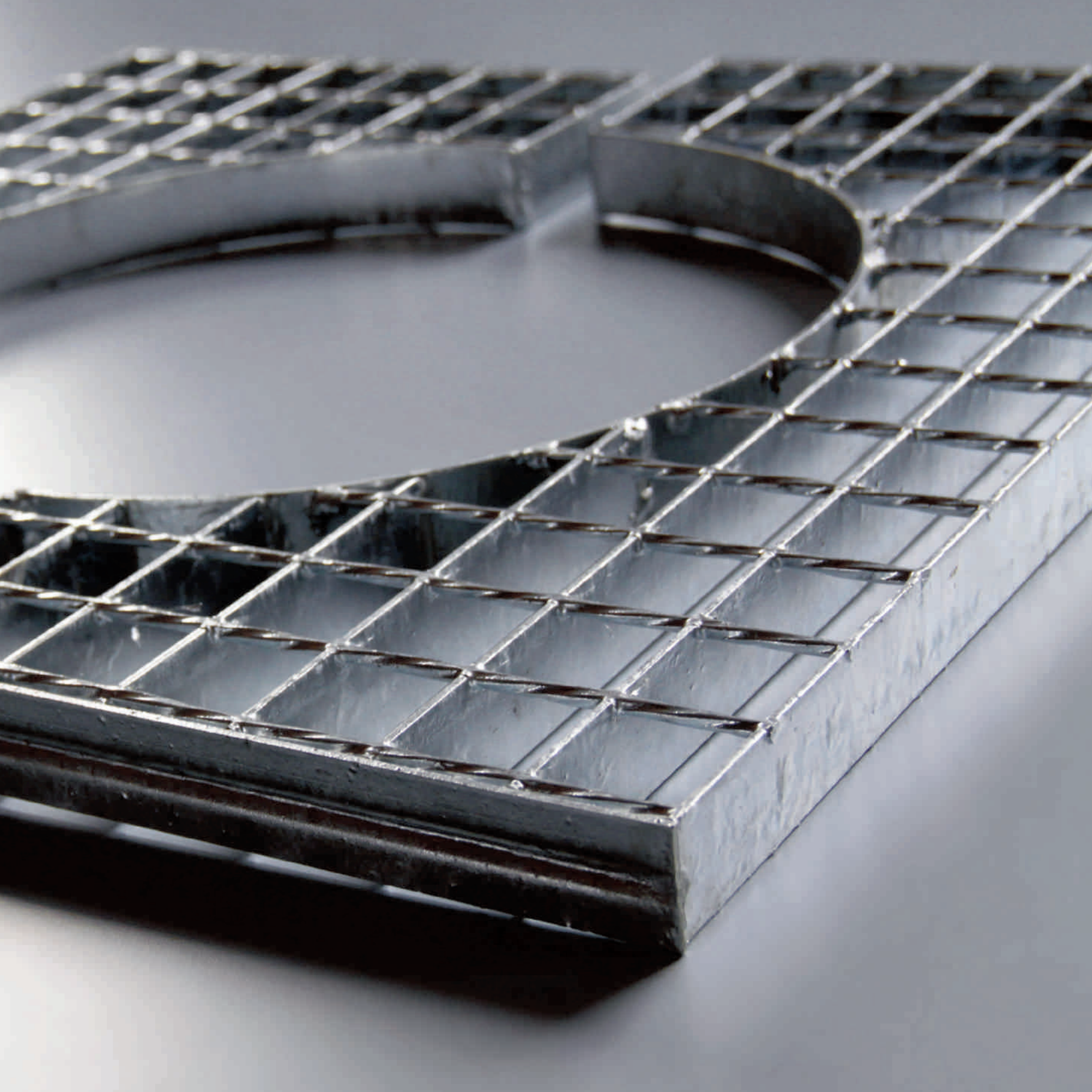

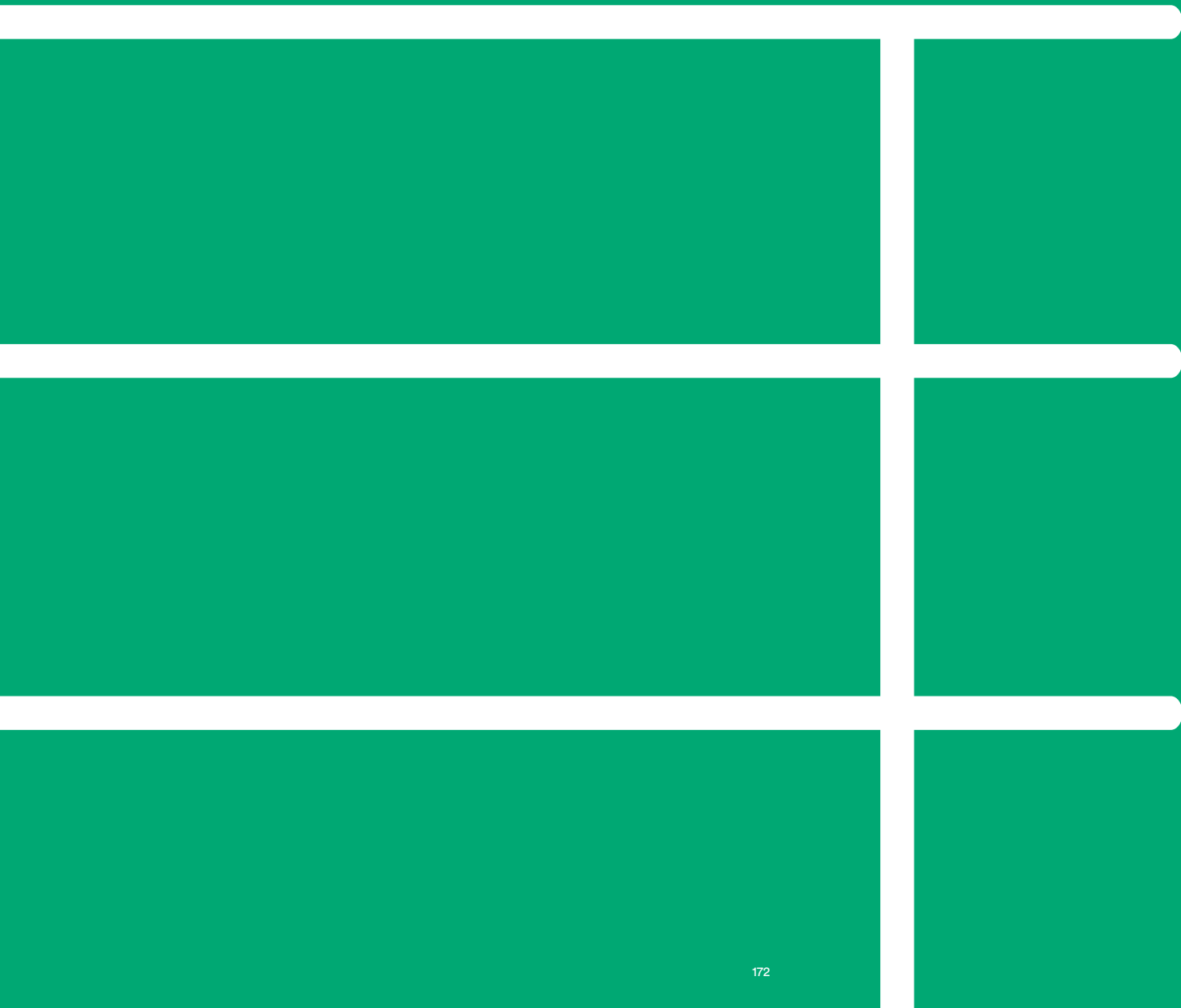

Acero | Acier | Steel



VVL02
LUNA

P. 174-175

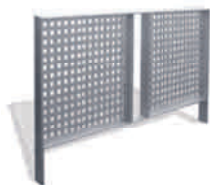

VVBA210
ENSANCHE

P. 176-177

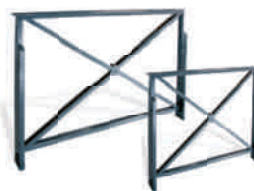

VVBA164
ST. ANDRÉ

P. 178



VVP001
SOL

P. 179



VVP004
PROTECTOR

P. 179



VV9005
CHAMBERÍ

P. 179



VVP008
NUDO

P. 179

Madera | Bois | Wood



VRV440
RÚSTICA

P. 180-181



VRV470R
PLANA

P. 180-181



VRV460
RURAL

P. 180-181

Luna

By BENITO ©

Acero zincado con imprimación epoxi y pintura poliéster en polvo color granate RAL 3004. Tubo de acero inox AISI-316 pulido brillante de Ø 51mm. Tubo de acero inox AISI-316 pulido brillante de Ø34mm. Separación standard de los postes: 2m. Anclaje: Mediante tres pernos de expansión de M10.

Acier zingué avec couche primaire époxy et thermolaquage polyester teinte grenat RAL 3004. Tube en acier inoxydable AISI-316 poli brillant de Ø 51mm. Tube en acier inoxydable AISI-316 poli brillant de Ø 34mm. Séparation standard des poteaux : 2 m. Ancrage : Par trois boulons à expansion M10.

Galvanised steel with epoxy primer coating and maroon RAL 3004 finish. Ø 51mm shiny, polished AISI-316 stainless steel tube. Ø 34mm shiny, polished AISI-316 stainless steel tube. Standard separation between posts: 2m. Anchoring: Three M10 expansion bolts.



VVL02

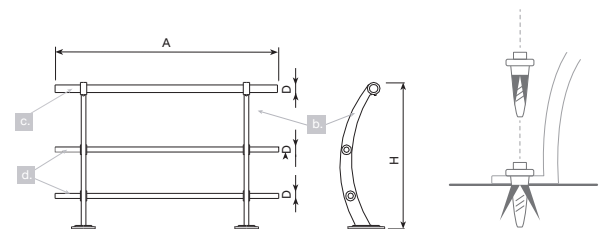

	Ref.	A	H	H1	D
b.	VVL02	-	1000 mm	-	24 mm
c.	VVL03	-	-	-	Ø51 mm
d.	VVL04	-	-	-	Ø34 mm



Ensanche

By Francisco Cerdán © BENITO



Acero zincado electrolítico por inmersión con una posterior imprimación en epoxi-zinc y pintura poliéster en polvo color gris plata RAL 9006. Anclaje recomendado: Mediante anclaje en hormigón.

Acier zingage électrolytique par immersion avec application ultérieure d'une couche primaire époxy-zinc et thermolaquage polyester gris RAL 9006. Ancrage recommandé : par ancrage dans le béton.

Steel electro-galvanised by immersion with epoxy-zinc primer coating and silver grey RAL 9006 polyester powder coated finish. Recommended anchoring: concrete foundation.

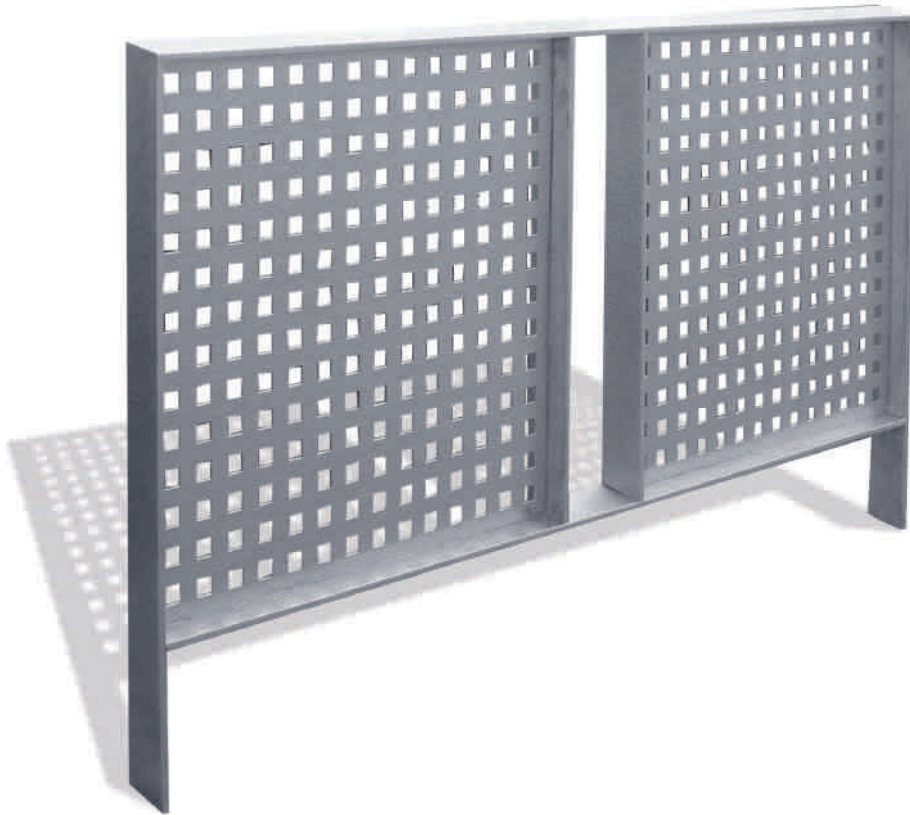

VVBA210

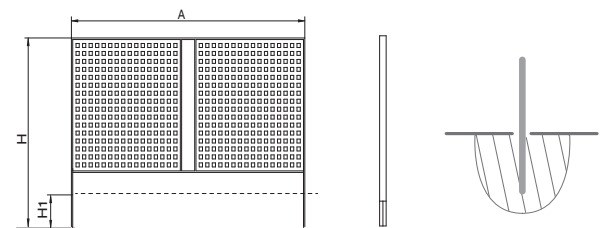

Ref.	A	H	H1
VVBA210	1790 mm	1195 mm	200 mm

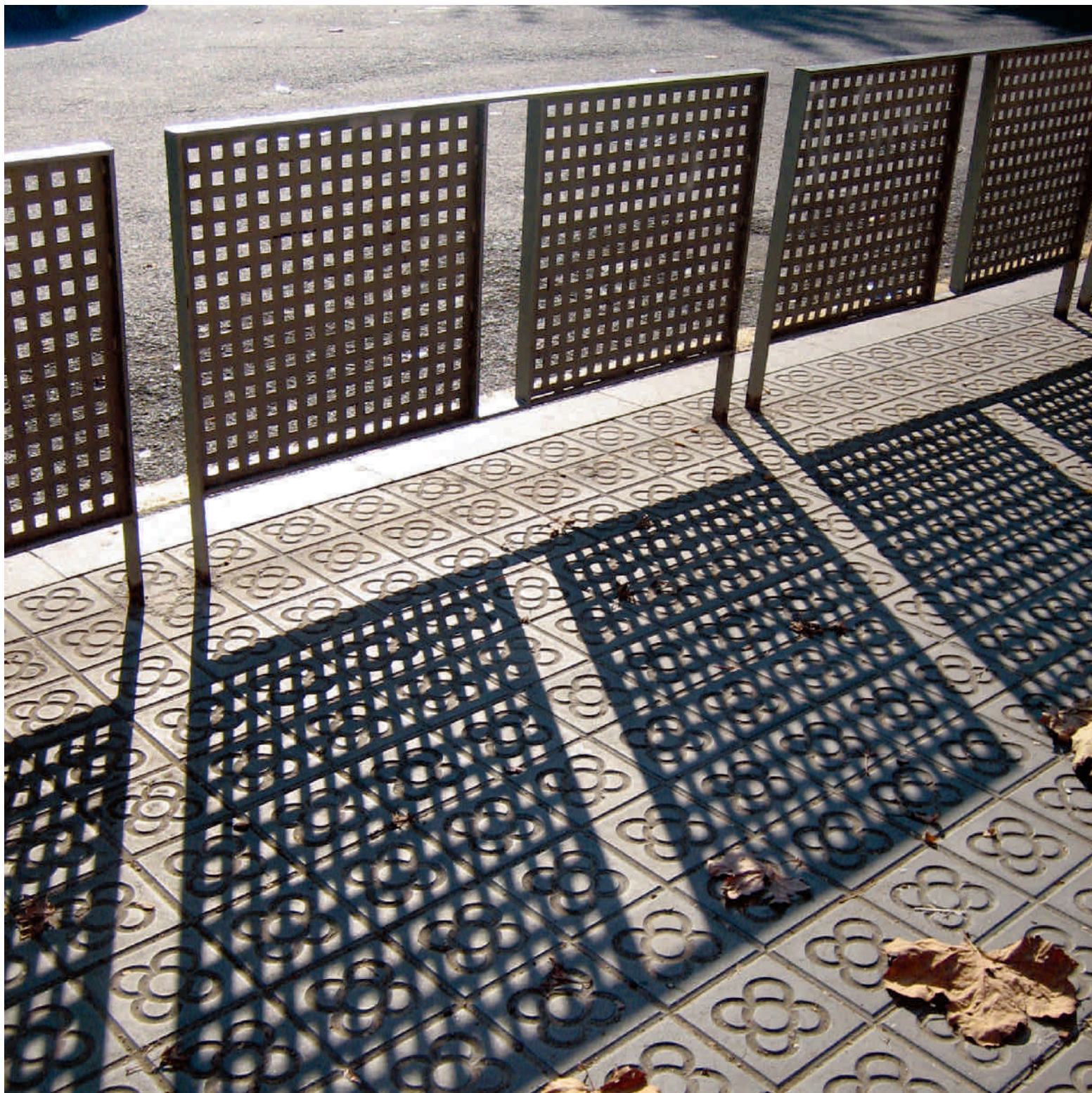

St-André

VVBA84



*VVBA84M/1
*VVBA164M/1



VVBA164

Acero galvanizado. Acabado imprimación epoxi y pintura poliéster en polvo color gris RAL 7016. Anclaje recomendado: Mediante anclaje en hormigón. Opcional: con base extraíble (VVBA84M/1 i VVBA164M/1S)

Acier galvanisé. Finition couche primaire époxy et thermo-laquage polyester gris RAL 7016. Ancrage recommandé: Par ancrage dans le béton. En option: avec clé amovible (VVBA84M/1 i VVBA164M/1S) .

Galvanised iron steel with epoxy primer coating and grey RAL 7016 polyester powder coated finish. Recommended anchoring: Concrete foundation. Optional: removable key (VVBA84M/1 i VVBA164M/1S)

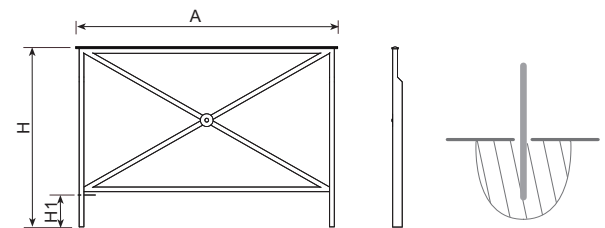

Ref.	A	H	H1
VVBA84	840 mm	1130 mm	200 mm
VVBA164	1640 mm	1130 mm	200 mm

*Opcional | En Option | Optional

Sol

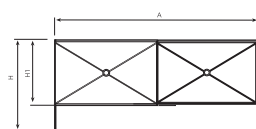

Ref.	A	H	H1	
VVP002	2000 mm	1110 mm	830 mm	✓
VVP001	2400 mm	1025 mm	740 mm	✓



VVP002

Protector

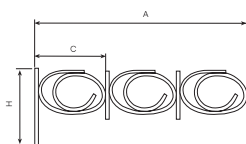

Ref.	A	C	H
VVP004	1115 mm	375 mm	520 mm



VVP004

Chamberí

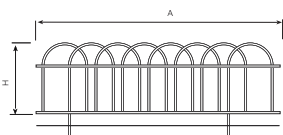

Ref.	A	H
VVP005	3000 mm	400 mm



VVP005

Nudo

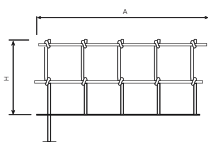

Ref.	A	H	
VVP008	∞	300 mm	✓
VVP009	∞	400 mm	✓



VVP008



VVP009

Rústica

Madera de pino con tratamiento autoclave a vacío-presión clase 4 contra la carcoma, termitas e insectos. Postes de Ø120 x 1500mm. Travesaños de Ø80 x 2000mm. Barrotes de media caña de Ø90mm.

Bois de pin traité en autoclave sous vide d'air classe 4 contre les vers à bois, les termites et les insectes. Poteaux de Ø 120 x 1500mm. Traverses de Ø80 x 2000 mm. Barreaux demi-cercle de Ø90mm.

Pine wood vacuum-pressure treated in an autoclave (Class 4) against woodworm, termites and insects. Ø120 x 1500mm posts. Ø80 x 2000mm crossbeams. Ø90mm semi-circular bars.

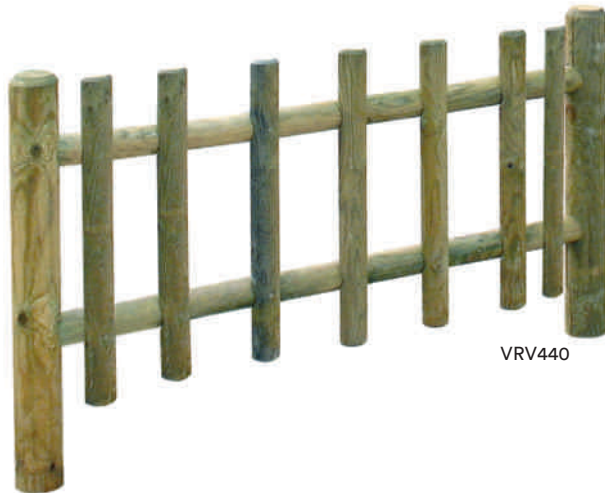

VRV440

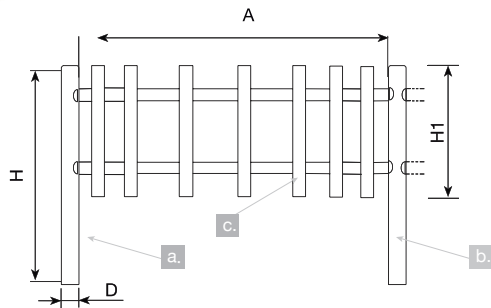

	Ref.	A	H	H1	D
c.	VRV440/T	2000 mm	1000 mm	800 mm	-

Plana

Madera de pino con tratamiento autoclave a vacío-presión clase 4 contra la carcoma, termitas e insectos. Postes verticales de 1170 x 90mm. Lamas con cantos redondeados. Opcional: Puerta valla Rústica Plana 1m (VRV470PR).

Pin avec traitement autoclave à pression à vide, classe 4, contre la vermoulure, les termites et les insectes. Poteaux verticaux de 1170 x 90 mm. Lames avec angles arrondis.

Pinewood vacuum and pressure autoclave treated wood against woodworm, termite and insect. 4 Class. Greenish colour finishing. 1170 x 90mm vertical poles. Round-edge slats. Optional: Door fence Rústica Plana 1m (VRV470PR).



VRV470R

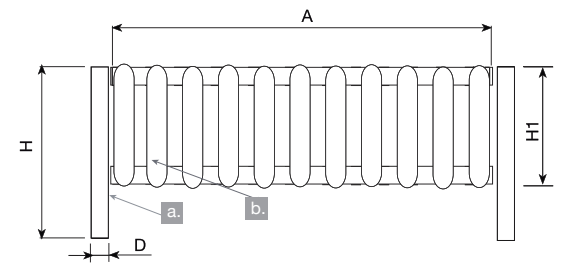

	Ref.	A	H	H1	D
a.	VRV470/PR	-	1170 mm	-	90 mm
b.	VRV470/TR	1950 mm	-	700 mm	-

Rural

Madera de pino con tratamiento autoclave a vaciopresión clase 4 contra la carcoma, termitas e insectos. Postes de Ø120 x 1500mm. Travesaños de Ø80 x 2000mm.

Bois de pin traité en autoclave sous vide d'air classe 4 contre les vers à bois, les termites et les insectes. Poteaux de Ø 120 x 1500mm. Traverses de Ø80 x 2000 mm.

Pine wood vacuum-pressure treated in an autoclave (Class 4) against woodworm, termites and insects. Ø120 x 1500mm posts. Ø80 x 2000mm crossbeams.



VRV460

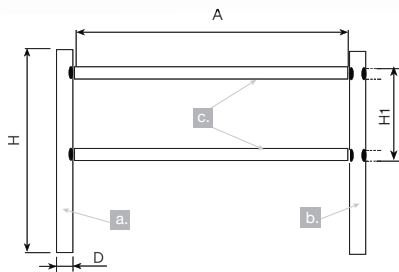

	Ref.	A	H	H1	D
a.	VRV460/P1	-	1500 mm	-	Ø120 mm
b.	VRV460/P	-	1500 mm	-	Ø120 mm
c.	VRV460/T	2000	-	500 mm	-



Sabías que... la madera natural “respira” es decir, absorbe y desprende la humedad en ambiente seco. Por lo tanto, es normal que puedan aparecer grietas en la madera. No influencia para nada en su capacidad de resistencia y su durabilidad. P. 10

Saviez vous que... le bois naturel “respire”, c’est-à-dire, qu’il absorbe et restitue de l’humidité dans une atmosphère sèche. Il est par conséquent normal que des fissures apparaissent dans le bois. Ceci n’influence en rien sa capacité de résistance et sa durabilité. P. 10

Did you know... natural wood “breathes” i.e. it absorbs humidity and releases it in dry atmospheres. It is therefore normal for cracks to appear in wood. This has no effect whatsoever on its strength and durability. P. 10



Acero | Acier | Steel

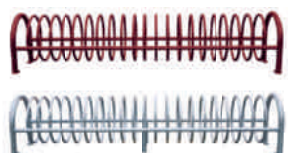

VBM20R
MEY

P. 184-185



VBF06
ARVELO

P. 186



VBO1
OMEGA

P. 187



VBU01
UNIVERSAL

P. 187

Mey

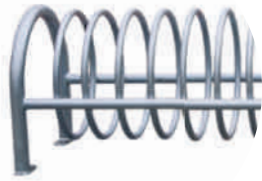

VBM20 RAL 9006

Acero zincado electrolítico. Acabado imprimación epoxi y pintura poliéster en polvo color granate RAL 3004. Anclaje: Mediante 4 pernos de expansión M8.

Acier zingage électrolytique. Finition couche primaire époxy et thermolaquage polyester RAL 3004. Ancrage: Par 4 boulons à expansion M8.

Electro-galvanised steel. Epoxy primer and color RAL 3004 polyester powder coated finish. Anchoring: Four M1 anision bolts.

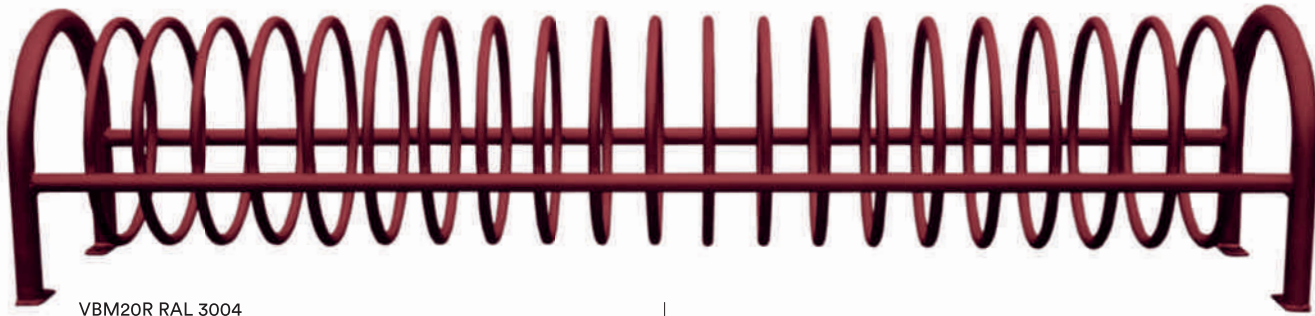

VBM20R RAL 3004

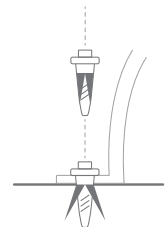
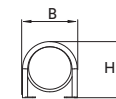
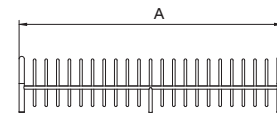

Ref.	A	B	H
VBM20R	2040 mm	435 mm	425 mm



Arvelo

By BENITO ©

Acero galvanizado en caliente. Anclaje: Mediante pernos de expansión M8.

Acier galvanisé à chaud. Ancrage: Par boulons à expansion M8.

Hot-dip galvanised steel. Anchoring: M8 expansion bolts.

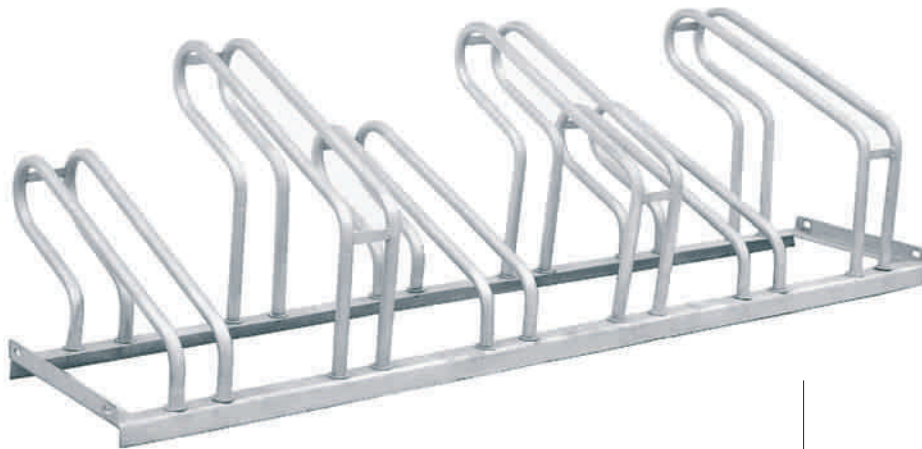

VBF06

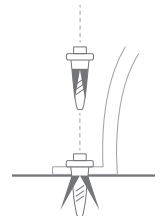
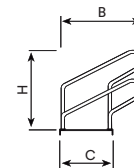
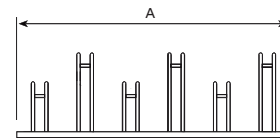

Ref.	A	B	C	H
VBF06	1800 mm	550 mm	350 mm	500 mm

Omega

By BENITO ©

Acero zincado electrolítico. Acabado imprimación epoxi y pintura poliéster en polvo color gris RAL 9006. Anclaje: Mediante 4 pernos de expansión M8. Opcional: En acero inoxidable (VBO1I).

Acier zingage électrolytique. Finition couche primaire époxy et thermolaquage polyester gris RAL 9006. Anclage: Par 4 boulons à expansion M8. En option: En acier inoxydable (VBO1I).

Electro-galvanised steel. Epoxy primer and grey RAL 9006 polyester powder coated finish. Anchoring: Four M8 expansion bolts. Optional: In stainless steel (VBO1I).

Ref.	A	B	H
VBO1	905 mm	100 mm	695 mm
VBO1I	905 mm	100 mm	695 mm

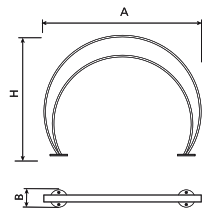

Universal

Acero galvanizado. Anclaje recomendado: Mediante anclaje en hormigón. Opcional: En acero inoxidable (VBU01I).

Acier galvanisé. Anclage recommandé : Anclage dans le béton. En option : En acier inoxydable (VBU01I).

Galvanised steel. Recommended anchoring: Concrete foundation. Optional: In stainless steel (VBU01I).

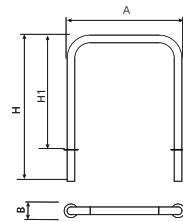

Ref.	A	B	H	H1
VBU01	790 mm	Ø90 mm	955 mm	750 mm
VBU01I	790 mm	Ø90 mm	955 mm	750 mm



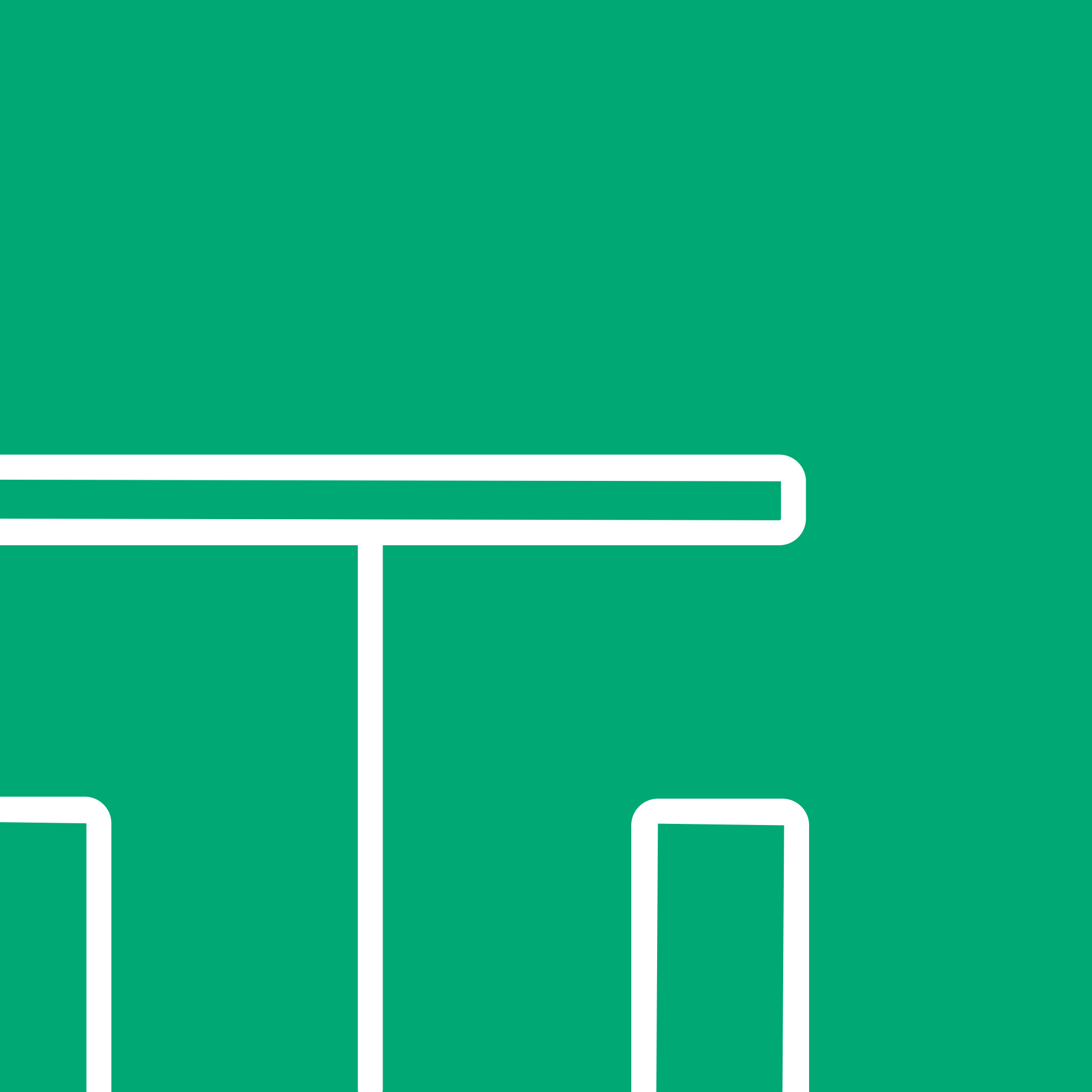

Madera tratada | Bois traité | Trated wood



VRM200N
PICNIKIDS

P. 194



VRM200
PICNIK

P. 194



VRM201
NATURE

P. 195

Madera + Acero | Bois + Acier | Wood + Steel



VM314
OLEA

P. 191



VM311
GAVARRES

P. 190



VMA01
PLAYER

P. 197

Hormigón | Betón prefabricado | Concrete



UM372M
KUBE

P. 196



VRM210M
PIK

P. 192



VRM215M
KUK

P. 192

reBnew





VM311

Otros productos Gavarres
Autres produits Gavarres
Other Gavarres range products



Gavarres

By Martí Franch © BENITO



Madera de pino tratada en autoclave a vacío-presión clase 4 contra la carcoma, termitas e insectos. Tornillería de acero inoxidable. Pies en plancha de acero corten de 8 mm. Anclaje recomendado: Mediante pernos de expansión M10.

_ Sabias que... la madera natural "respira" és decir, absorbe y desprende de la humedad en ambiente seco. Por lo tanto, és normal que puedan aparecer grietas en la madera. No influencia para nada en su capacidad de resistencia y su durabilidad.

_ La oxidación del acero corten evoluciona con el paso del tiempo y se oxida, más o menos rapido, en función de la temperatura ambiente y la humedad.

Bois de pin traité en autoclave sous vide d'air classe 4 contre les vers à bois, les termites et les insectes. Vis en acier inoxydable. Piètement en tôle d'acier Corten de 8 mm. Ancre recommandé : Par des boulons à expansion M10.

Saviez vous que... le bois naturel "respire", c'est-à-dire, qu'il absorbe et restitue de l'humidité dans une atmosphère sèche. Il est par conséquent normal que des fissures apparaissent dans le bois. Ceci n'influence en rien sa capacité de résistance et sa durabilité.

_ L'oxydation de l'acier évoluera au fil du temps, et sera plus ou moins rapide en fonction de la température ambiante et de l'humidité.

Pine wood vacuum-pressure treated in an autoclave (Class 4) against woodworm, termites and insects. Stainless steel bolts. 8mm Corten steel supports. Anchoring: M10 expansion bolts.

Did you know... natural wood "breathes" i.e. it absorbs humidity and releases it in dry atmospheres. It is therefore normal for cracks to appear in wood. This has no effect whatsoever on its strength and durability.

_ The rustiness from Corten steel evolves overtime, which means that this material sooner or later will get rusty depending on the humidity and temperature levels.

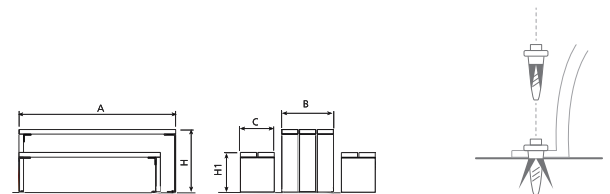

Ref.	A	B	C	H	H1
VM311	2040 mm	670 mm	400 mm	810 mm	440 mm

Olea

Pies tubulares de acero corten de 50 × 100 mm. Tablones de sección 210 × 50 mm en madera de pino tratada en autoclave vacío-presión clase 4 contra la carcoma, termitas e insectos. Tornillería de acero inoxidable. Anclaje recomendado: Tornillos de fijación al suelo de M10 según superficie y proyecto.

_ Sabias que... la madera natural "respira" és decir, absorbe y desprende la humedad en ambiente seco. Por lo tanto, es normal que puedan aparecer grietas en la madera. No influencia para nada en su capacidad de resistencia y su durabilidad.

_ La oxidación del acero corten evoluciona con el paso del tiempo y se oxida, más o menos rapido, en función de la temperatura ambiente y la humedad.

Piètement en tôle d'acier Corten de 50 × 100 mm. Lattes de section 210 × 50 mm en bois de pin traité en autoclave sous vide d'air (classe 4 contre les vers à bois, les termites et les insectes). Vis en acier inoxydable. Ancrage recommandé: vis M10 pour la fixation au sol, en fonction de la surface et du projet.

_ Saviez vous que... le bois naturel "respire", c'est-à-dire, qu'il absorbe et restitue de l'humidité dans une atmosphère sèche. Il est par conséquent normal que des fissures apparaissent dans le bois. Ceci n'influence en rien sa capacité de résistance et sa durabilité.

_ L'oxydation de l'acier évoluera au fil du temps, et sera plus ou moins rapide en fonction de la température ambiante et de l'humidité.

Legs in 50 × 100 mm untreated corten steel. 210 × 50 mm pine wood boards, vacuum-pressure treated in autoclave (class 4) against woodworm, termites and insects. Stainless steel bolts. Recommended anchoring: M10 bolts to anchor to the ground, depending on the surface and the project.

_ Did you know... natural wood "breathes" i.e. it absorbs humidity and releases it in dry atmospheres. It is therefore normal for cracks to appear in wood. This has no effect whatsoever on its strength and durability.

_ The rustiness from Corten steel evolves overtime, which means that this material sooner or later will get rusty depending on the humidity and temperature levels.



VM314

* Acabado imprimación epoxi y pintura poliéster en polvo color MARSON.

* Finition couche primaire époxy et thermolaquage polyester teinte MARSON.

* Epoxy primer coating and MARSON polyester powder coated finish.

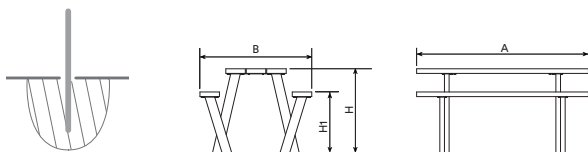

Ref.	A	B	H	H1
VM314	1850 mm	1203 mm	910 mm	660 mm

*Opcional | En Option | Optional

Otros productos Olea
Autres produits Olea
Other Olea range products



reBnew

Productos 100% plástico reciclado Rebnew
 Produits 100% plastique recyclé Rebnew
 Products 100% recycled plastic Rebnew



VRM210M

Otros productos ReBnew
 Autres produits ReBnew
 Other ReBnew range products



Pik

Resistencia a la intemperie. Resistente a aceites, ácidos y agua de mar. No se degrada. No se astilla. Antigraffiti. Resistente a la humedad, no absorbe agua, de secado rápido. ECOLÓGICO proviene de producto reciclado y a la vez es reciclable. Larga vida útil. 100% Reciclable. Sin contaminantes. Fabricado de plásticos reciclados de alta calidad.

PREMIADO CON “DER BLAUE ENGEL” Producto con baja incidencia ambiental durante su ciclo de vida.

Résistant aux intempéries. Résistant aux huiles, acides et eau de mer. Ne se dégrade pas. Anti-graffiti. Résistant aux humidité, n'absorbe pas l'eau, sèche rapidement. ECOLOGIQUE, provient de matière recyclée et est également recyclable. Longue vie utile. 100% Recyclable. Sans contaminants. Fabriqué à partir de plastiques recyclés de haute qualité.

PRIX “DER BLAUE ENGEL”. Produit à faible impact environnemental durant son cycle de vie.

Weather resistant. Oil, acid & seawater resistant. It does not degrade. It doesn't splinter. Anti-graffiti. High resistance to hard weather conditions, no water absorption & fast drying. ENVIRONMENTALLY FRIENDLY, it comes from recycled material and is recyclable too. Long lifespan. 100% Recyclable. No pollutants. Made of high quality recycled plastic.

Awarded “DER BLAUE ENGEL” Product with low environmental impact during its life cycle.

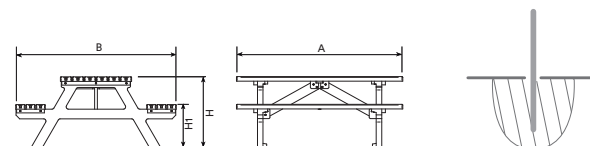

Ref.	A	B	H	H1
VRM210M	1800 mm	1738 mm	760 mm	460 mm

Kuk

Resistencia a la intemperie. Resistente a aceites, ácidos y agua de mar. No se degrada. No se astilla. Antigraffiti. Resistente a la humedad, no absorbe agua, de secado rápido. ECOLÓGICO proviene de producto reciclado y a la vez es reciclable. Larga vida útil. 100% Reciclable. Sin contaminantes. Fabricado de plásticos reciclados de alta calidad.

PREMIADO CON “DER BLAUE ENGEL” Producto con baja incidencia ambiental durante su ciclo de vida.

Résistant aux intempéries. Résistant aux huiles, acides et eau de mer. Ne se dégrade pas. Anti-graffiti. Résistant aux humidité, n'absorbe pas l'eau, sèche rapidement. ECOLOGIQUE, provient de matière recyclée et est également recyclable. Longue vie utile. 100% Recyclable. Sans contaminants. Fabriqué à partir de plastiques recyclés de haute qualité.

PRIX “DER BLAUE ENGEL”. Produit à faible impact environnemental durant son cycle de vie.

Weather resistant. Oil, acid & seawater resistant. It does not degrade. It doesn't splinter. Anti-graffiti. High resistance to hard weather conditions, no water absorption & fast drying. ENVIRONMENTALLY FRIENDLY, it comes from recycled material and is recyclable too. Long lifespan. 100% Recyclable. No pollutants. Made of high quality recycled plastic.

Awarded “DER BLAUE ENGEL” Product with low environmental impact during its life cycle.

reBnew

Productos 100% plástico reciclado Rebnew
Produits 100% plastique recyclé Rebnew
Products 100% recycled plastic Rebnew



VRM215M

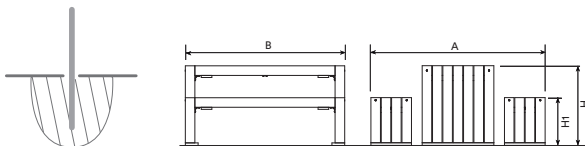

Ref.	A	B	H	H1
VRM215M	1500 mm	1441 mm	750 mm	450 mm

Otros productos ReBnew
Autres produits ReBnew
Other ReBnew range products



Picni *Kids*
VRM200N



VRM200

Otros productos en madera de pino
Autres produits en pin
Other products made of pinewood



P.70-71



P.151-153



P.124-125



P.99



P.180-181



P.180-181



P.180-181

Picnik

Madera de pino tratada en autoclave a vacío-presión clase 4 contra la carcoma, termitas, insectos. Tablones de 1940 x 95 x 45mm.

Sabías que... la madera natural "respira" es decir, absorbe y desprende la humedad en ambiente seco. Por lo tanto, es normal que puedan aparecer grietas en la madera. No influencia para nada en su capacidad de resistencia y su durabilidad. P. 10

Bois de pin traité en autoclave à vide-pression classe 4 contre les vers à bois, les termites et les insectes. Lattes de 1940 x 95 x 45mm.

Saviez vous que... le bois naturel "respire", c'est-à-dire, qu'il absorbe et restitue de l'humidité dans une atmosphère sèche. Il est par conséquent normal que des fissures apparaissent dans le bois. Ceci n'influence en rien sa capacité de résistance et sa durabilité. P. 10

Pine wood vacuum-pressure treated in an autoclave (Class 4) against woodworm, termites and insects. 1940 x 95 x 45mm wood boards.

Did you know... natural wood "breathes" i.e. it absorbs humidity and releases it in dry atmospheres. It is therefore normal for cracks to appear in wood. This has no effect whatsoever on its strength and durability. P. 10

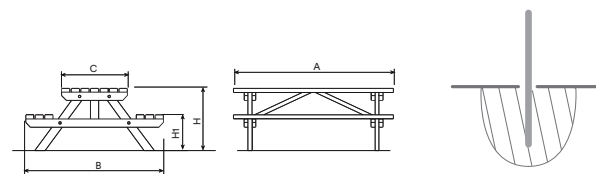

Ref.	A	B	C	H	H1
VRM200N	1500 mm	1680 mm	800 mm	710 mm	390 mm
VRM200	1940 mm	1680 mm	800 mm	765 mm	440 mm



Nature

Madera de pino tratada en autoclave a vacío-presión clase 4 contra la carcoma, termitas, insectos. Tablones de 1940 x 95 x 45mm.

Sabias que... la madera natural "respira" es decir, absorbe y desprende la humedad en ambiente seco. Por lo tanto, es normal que puedan aparecer grietas en la madera. No influencia para nada en su capacidad de resistencia y su durabilidad. P. 10

Bois de pin traité en autoclave à vide-pression classe 4 contre les vers à bois, les termites et les insectes. Lattes de 1940 x 95 x 45mm.

Saviez vous que... le bois naturel "respire", c'est-à-dire, qu'il absorbe et restitue de l'humidité dans une atmosphère sèche. Il est par conséquent normal que des fissures apparaissent dans le bois. Ceci n'influence en rien sa capacité de résistance et sa durabilité. P. 10

Pine wood vacuum-pressure treated in an autoclave (Class 4) against woodworm, termites and insects. 1940 x 95 x 45mm wood boards.

Did you know... natural wood "breathes" i.e. it absorbs humidity and releases it in dry atmospheres. It is therefore normal for cracks to appear in wood. This has no effect whatsoever on its strength and durability. P. 10



VRM201

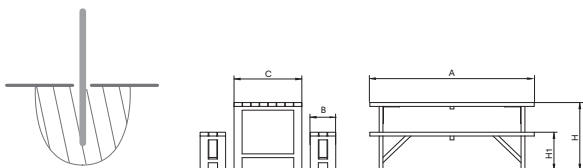

Ref.	A	B	C	H	H1
VRM201	1940 mm	300 mm	800 mm	800 mm	450 mm



P.70-71



P.151-153



P.124-125

P.99



P.180-181



P.180-181



P.180-181

Otros productos en madera de pino
Autres produits en pin
Other products made of pinewood



Kube



Hormigón prefabricado color gris granítico de aspecto liso. Se puede colocar en elementos aislados o en grupos. Anclaje recomendado: Apoyado por su propio peso.

Béton préfabriqué gris granite, aspect lisse. Peut être placé séparément ou en groupes. Ancrage recommandé : posé à terre.

Pre-cast smooth granite grey concrete. May be positioned individually or in groups. Recommended anchoring: free-standing.



UM372M

Otros productos Kube
Autres produits Kube
Other Kube range products

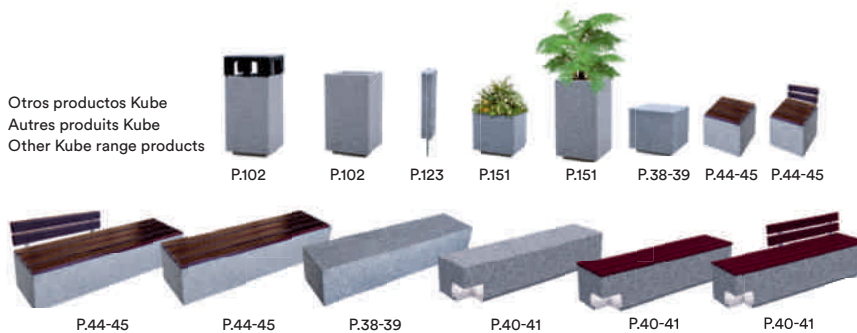

P.102

P.102

P.123

P.151

P.151

P.38-39

P.44-45

P.44-45

P.44-45

P.44-45

P.38-39

P.40-41

P.40-41

P.40-41

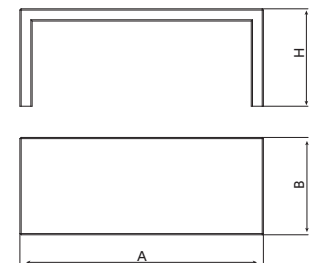

Ref.	A	B	H
UM372M	2000 mm	800 mm	750 mm

Player

Tablones de madera tropical. Estructura tubular de acero de Ø40 mm. Acabado: estructura de acero en poliéster al horno color negro. Madera con tratamiento protector fungicida, insecticida e hidrófugo. Acabado color natural. Opcional: El tablero puede personalizar. Solicite información.

Bancs en tropical. Structure tubulaire en acier de Ø40 mm de diamètre. Finition: structure en acier, peinture polyester au four, couleur noire. Bois tropical traité avec Lignusprotecteur fongicide, insecticide et hydrofuge. Finition couleur naturelle. En option: Jeu personnalisable, demander information.

Made of tropical wood . Ø40mm steel tube framework. Finishing: steel framework in hot dip black colour polyester coated. Made of tropical wood treated with Lignus, a fungicide, insecticide and waterproofing agent termite and insects. natural colour finish. Optional: This product can be customized on demand. Please request further information.



VMA01



* VMA02

* VMA03

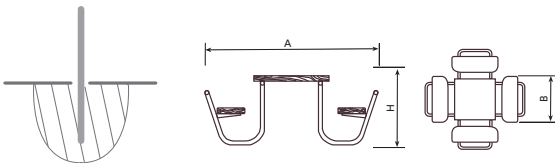

Ref.	A	B	H	H1
VMA01	1850 mm	900 mm	600 mm	-

*Opcional | En Option | Optional

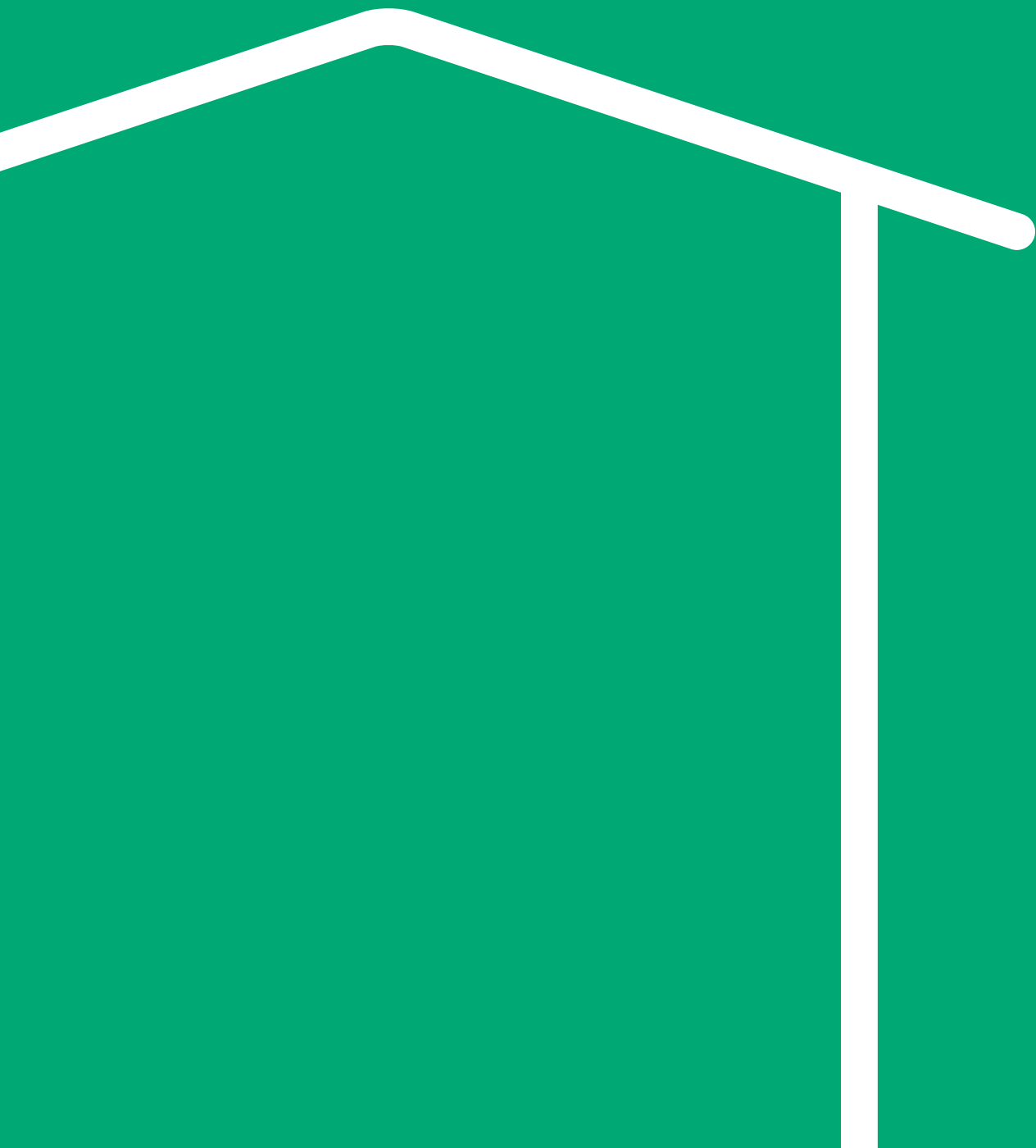

Madera de pino | Bois en pin | Pinewood



VRP2400
SAHARA

P. 200



VRP3400
KALAHARI

P. 201



VRP4600G
THAR

P. 202-203

Acero inoxidable | Acier inoxydable | Stainless Steel



MA01
STIL

P. 204



VRP3400
IRIS

P. 205



Sahara

Pérgola autoportante 2 aguas de 4000x4000 en madera de pino Oregón Europeo (Douglas): pilares de 120 x 120 mm, vigas de 170 x 45 mm, viguetas de 140 x 45 mm y tabla machihembrada de 115 x 21 mm. Acabado lasur, 100% natural a base de aceites y resinas vegetales, con protector ultravioleta color roble dorado. Cubierta asfáltica (tegola americana) color marrón otoño. Tornillería de acero inoxidable y anclajes galvanizados en caliente. Kit individual de montaje.

Pérgola autoportante double pente, de 4000 x 4000 mm, bois en pin d'Oregon européen (Douglas) : poteaux de 120 x 120 mm, poutres de 170 x 45 mm, poutrelles de 140 x 45 mm et plaque emboîtée de 115 x 21 mm. Finition lasure, 100% naturelle, à base d'huiles et de résines végétales, avec protection contre les ultraviolets, coloris chêne doré. Couverture en bardeau bitumé, coloris marron automne. Visserie en acier inoxydable et ancrages galvanisés à chaud. Kit individuel de montage.

4000 x 4000 mm self-supporting gable roof pergola, made from European Oregon (Douglas) pinewood. 120 x 120 mm pillars, 170 x 45 mm beams, 140 x 45 mm joists and 115 x 21 mm tongue-and-groove boards. Lasur coating, 100% natural plant oil- and resin-based varnish finish, with a protective UV overcoat in golden oak colour. Asphalt roof (asphalt shingles) in autumn brown colour. Stainless steel fasteners and hot-galvanised steel anchors. Individual assembly kit.



VRP2400

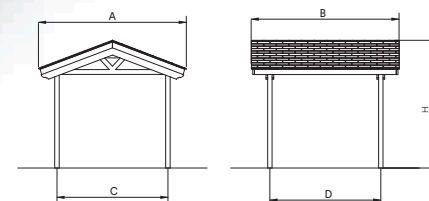

Ref.	A	B	C	D	H
VRP2400	4000 mm	4000 mm	3000 mm	3000 mm	3200 mm

Kalahari

Pérgola de 4000x4000 en madera de pino Oregón Europeo (Douglas): pilares de 90x90, vigas de 140x45, viguetas de 100x45 y tabla machihembrada de 115x21. Acabado lasur, 100 % natural a base de aceites y resinas vegetales, con protector ultravioleta color roble dorado. Cubierta asfáltica (tela asfáltica) color marrón otoño. Tornillería de acero inoxidable y anclajes galvanizados en caliente. Kit individual de montaje.

Pergola autoportante double pente, de 4 000 x 4 000, en pin d'Oregon européen (Douglas) : poteaux de 90 x 90, poutres de 140 x 45, poutrelles de 100 x 45 et plaque emboîtée de 115 x 21. Finition lasure, 100 % naturelle, à base d'huiles et de résines végétales, avec protection contre les ultraviolets, coloris chêne doré. Couverture en bardeau bitumé, coloris marron automne. Visserie en acier inoxydable et ancrages galvanisés à chaud. Kit individuel de montage.

4000 x 4000 self-supporting gable roof pergola, made from European Oregon (Douglas) pine. 90 x 90 pillars, 140 x 45 beams, 100 x 45 joists and 115 x 21 tongue-and-groove boards. Lasur coating, 100% natural plant oil- and resin-based varnish finish, with a protective UV overcoat in golden oak colour. Asphalt roof (asphalt shingles) in autumn brown colour. Stainless steel fasteners and hot-galvanised steel anchors. Individual assembly kit.

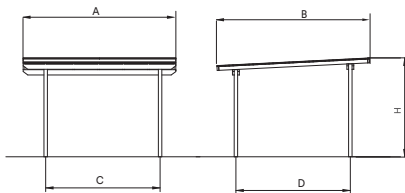

Ref.	A	B	C	D	H
VRP3400	4000 mm	4000 mm	3000 mm	3000 mm	2590 mm

Thar

Pérgola autoportante 2 aguas de 6000×3000 en madera de pino Oregón Europeo (Douglas): pilares de 90×90, vigas de 170×45, viguetas de 140×45 y tabla machihembrada de 115×21. Acabado lasur, 100 % natural a base de aceites y resinas vegetales, con protector ultravioleta color gris. Cubierta asfáltica (tegola americana) color marrón otoño. Tornillería de acero inoxidable y anclajes galvanizados en caliente. Kit individual de montaje. Opcional: VRP4600 (lasur color roble dorado).

Pergola autoportante double pente, de 6000 × 3000, bois en pin d'Oregon européen (Douglas) : poteaux de 90 × 90, poutres de 170 × 45, poutrelles de 140 × 45 et plaque emboîtée de 115 × 21. Finition lasure, 100 % naturelle, à base d'huiles et de résines végétales, avec protection contre les ultraviolets, coloris gris. Couverture en bardeau bitumé, coloris marron automne. Visserie en acier inoxydable et ancrages galvanisés à chaud. Kit individuel de montage. En option : VRP4600 (lasure coloris chêne doré)



6000 × 3000 self-supporting gable roof pergola, made from European Oregon (Douglas) pinewood. 90 × 90 pillars, 170 × 45 beams, 140 × 45 joists and 115 × 21 tongue-and-groove boards. Lasur coating, 100% natural plant oil- and resin-based varnish finish, with a protective UV overcoat in grey colour. Asphalt roof (asphalt shingles) in autumn brown colour. Stainless steel fasteners and hot-galvanised steel anchors. Individual assembly kit. Optional: VRP4600 (lasur golden oak colour)

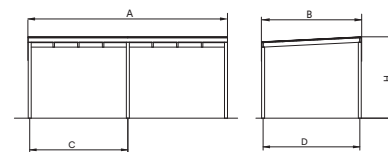

Ref.	A	B	C	C	H
VRP4600G	6000 mm	3000 mm	2955 mm	2910 mm	2450 mm



Stil

Pilares y banco de acero inoxidable AISI-304 pulido brillante. Panel tejado con tres pilares de 80 × 80mm, soporte para su fijación con escuadras y perfiles horizontales para cerramiento con cristal. Tejado inyectado poliuretano galvanizado y prelacado. Cristal laminado de seguridad. Entregado en kit con accesorios e instrucciones de montaje. Anclaje recomendado: Mediante empotramiento en el suelo. Opcional: Sin lateral (MA01). Con dos laterales (MA01/2). Cristal personalizado.

Poteaux et banc en acier inoxydable AISI-304 poli brillant. Panneau toit avec trois poteaux de 80 × 80mm, support pour la fixation avec équerres et profils horizontaux pour fermeture en verre. Toit injecté en polyuréthane galvanisé et prélaqué. Verre de sécurité laminé. Livré en kit avec les accessoires et les instructions de montage. Ancrage recommandé : par encastrement dans le sol. En option : Sans face latérale MA01, avec deux faces latérales MA01/2. Verre personnalisé.

Pillars and bench in shiny, polished AISI-304 stainless steel. Roof panel with three 80 × 80mm support pillars for its fixing, with squares and horizontal profiles for glass enclosure. Galvanised and pre-lacquered injected polyurethane roof. Laminated safety glass. Supplied in kit form, with accessories and assembly instructions. Recommended anchoring: Embedded in the ground. Optional: Without MA01 side, with two MA01/2 sides. Customised glass.



MA01

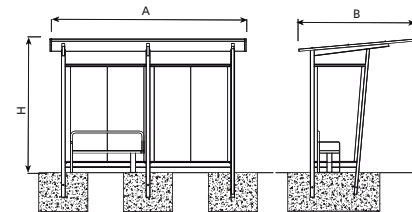

Ref.	A	B	H
MA01	4000 mm	2696 mm	2020 mm
MA01/1	4000 mm	2696 mm	2020 mm
MA01/2	4000 mm	2696 mm	2020 mm

Iris

Pilares y banco de acero inoxidable AISI-304 pulido brillante. Tejado con estructura tubular y panel de 8 mm. Tres pilares de 60 × 80mm de soporte para su fijación, atornillado en los perfiles laterales donde se monta el cerramiento con cristal. Tejado de acero inoxidable y panel de policarbonato. Cristal laminado de seguridad. Entregado en kit con accesorios e instrucciones de montaje. Anclaje recomendado: Mediante empotramiento en el suelo. Opcional: Con dos laterales MA02/2. Cristal personalizado.

Poteaux et banc en acier inoxydable AISI-304 poli brillant. Toit avec structure tubulaire et panneau de 8 mm. Trois poteaux de 60 × 80, support pour la fixation, vissés sur les profils latéraux où est montée la fermeture en verre. Toit en acier inoxydable et panneau en polyuréthane. Verre de sécurité laminé. Face latérale prévue pour l'insertion de publicité. Livré en kit avec les accessoires et les instructions de montage. Ancrage recommandé : Par encastrement dans le sol. En option : Avec deux faces latérales MA01/2. Verre personnalisé.

Pillars and bench in shiny, polished AISI-304 stainless steel. Roof with tubular structure and 8 mm panel. Three 60 × 80 support pillars for its fixing, bolted onto the side profiles where the glass enclosure is mounted. Stainless steel roof with polycarbonate panel. Laminated safety glass. Supplied in kit form, with accessories and assembly instructions. Recommended anchoring: Embedded in the ground. Optional: With two MA02/2 sides. Customised glass.



MA02/1

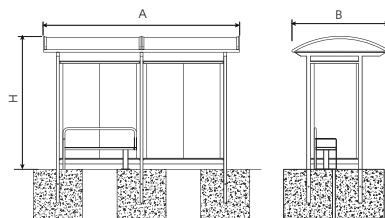

Ref.	A	B	H
MA02/1	4000 mm	1980 mm	2750 mm
MA02/2	4000 mm	1980 mm	2750 mm

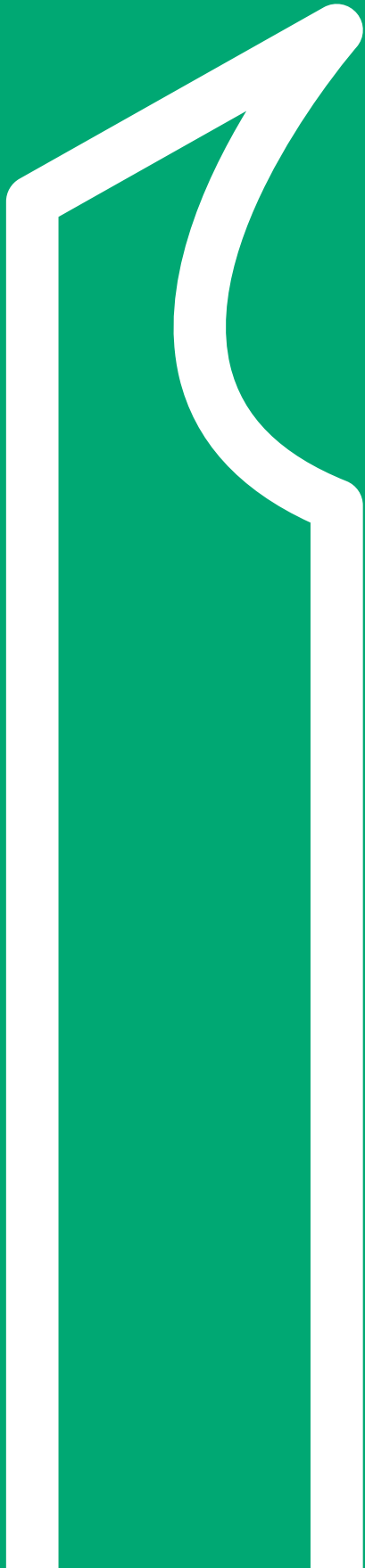

Complementos | Suppléments | Accessories



VC1
CLASH

P. 208



VC4
CLIP

P. 209



VTOG
TOILEKAN

P. 210



UM551
TERRIER

P. 211



VBA01
SLOW

P. 212



VBA20
VAI

P. 212



CSSI
CONTAIN

P. 213



VCC1
HIDE

P. 213



VBZ01
MEFA

P. 214

Clash

By BENITO ©

Cuerpo y cubeta en acero zincado con tratamiento Ferrus, proceso protector del hierro, que garantiza una óptima resistencia a la corrosión. Acabado imprimación epoxi y pintura poliéster en polvo color marrón RAL 8019. Parte superior apaga cigarrillos en acero inoxidable. Anclaje recomendado: Mediante cuatro pernos de expansión de M8.

Corps et corbeille en acier galvanisé avec traitement Ferrus, procédé qui protège l'acier et garantit une résistance optimale à la corrosion. Finition couche primaire époxy et thermolaquage polyester marron RAL8019. Cendrier en acier inoxydable dans la partie supérieure. Ancrage recommandé : Par des boulons à expansion M8.

Body and bin made of galvanised steel treated with Ferrus, a protective process for iron that guarantees high corrosion resistance. Epoxy primer coating and brown RAL 8019 polyester powder coated finish. Top includes a stainless steel cigarette stubber. Recommended anchoring: Four M8 bolts to anchor to the ground.



Fácil vaciado
Facile vidage
Easy emptying

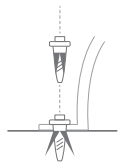
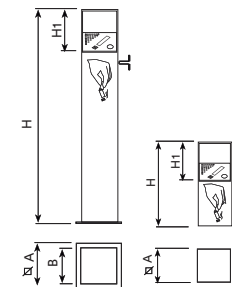

Ref.	A	B	H	H1
VC1	160 mm	120 mm	1000 mm	170 mm
VC2	120 mm	-	355 mm	170 mm

Clip

Acero con imprimación epoxi y pintura poliéster en polvo color negro forja (VC4) o gris RAL 7011 (VC4GR). Instalación: Mediante tornillos M6, tornillo de chapa, brida o taco químico. Adaptable a papeleras.

Acier avec couche primaire époxy et thermolaquage polyester noir de forge (VC4) ou gris RAL7011 (VC4GR). Installation : Par vis M6, vis à tôle, bride ou cheville chimique. Peut s'adapter aux poubelles.

Steel with epoxy primer coating and black wrought iron colour (VC4) or grey RAL 7011 (VC4GR) polyester powder coated finish. Fitting: M6 bolts, sheet metal screws, flanges or chemical anchors. Can be adapted to litter bins.

Fácil vaciado
Facile vidage
Easy emptying



VC4



VC4GR



Ref.	Ø A	B	H
VC4	Ø80 mm	-	270 mm
VC4GR	Ø80 mm	-	270 mm



Toilekan

By BENITO ©

Acero galvanizado con imprimación epoxi y pintura poliéster en polvo color verde RAL 6005. Cubeta interior para residuos con sistema de cierre automático. Dispensador de bolsas con sistema de cierre automático. Anclaje recomendado: Mediante cuatro pernos de expansión de M8. Opcional: Disponibilidad de suministro de bolsas de recambio. Cajas de 2.000 unidades (VTO-B).

Acier galvanisé avec couche primaire époxy et thermolaquage polyester vert RAL 6005. Corbeille intérieure pour déchets avec système de verrouillage automatique. Distributeur de sacs. Ancrage recommandé : Par 4 boulons à expansion M8. En option : Possibilité de fournir des sacs de recharge. Boite de 2.000 unités (VTO-B).

Galvanised steel with epoxy primer coating and green RAL 6005 polyester powder coated finish. Inner rubbish bin with automatic closure. Plastic bag dispenser. Anchoring: Four M8 bolts to anchor to the ground. Optional: Replacement bags can be supplied. Boxes of 2,000 bags (VTO-B).

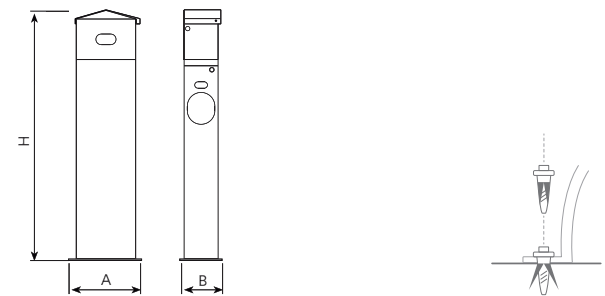

Ref.	A	B	H
VTOG	320 mm	200 mm	1200 mm



Terrier

La fuente Terrier, es una fuente diseñada exclusivamente para perros. Cuerpo de acero galvanizado pintado con pintura poliéster en polvo negro forja. Cubeta de acero inoxidable. Incluida grifería, flexo entrada de agua y tubería de desagüe. Anclaje recomendado: Mediante cuatro pernos de expansión de M8.

Fontaine créée exclusivement pour les chiens. Corps en acier galvanisé peint avec une peinture polyester en poudre noir forge. Réceptacle en acier inoxydable. Robinetterie incluse, flexo entrée d'eau et tubes de vidange. Fixation recommandée: Avec 4 vis d'expansion M8.

The Terrier fountain has been specifically designed for dogs. Body made of galvanised steel powder coated in black forge polyester paint. Inner liner made of stainless steel. Taps, water inlet flexor and pipe included. Recommended anchoring: 4xM8 expansion bolts.



UM551

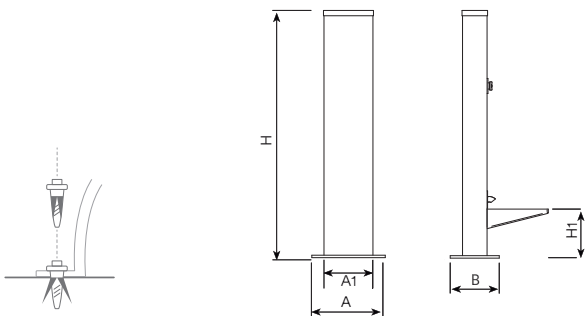

Ref.	A	A1	B	H	H1
UM551	300 mm	200 mm	100 mm	1010 mm	200 mm

Otros productos
Autres produits
Other range products



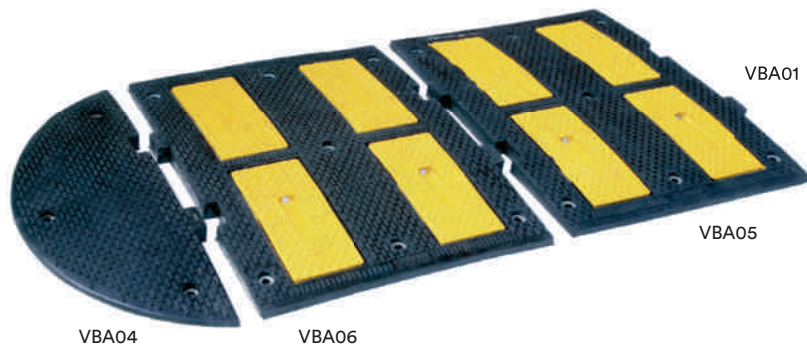

Ref.	A	B	H
VBA01	600 mm	475 mm	30 mm
VBA04	600 mm	240 mm	30 mm
VBA05	600 mm	475 mm	50 mm
VBA06	600 mm	240 mm	50 mm

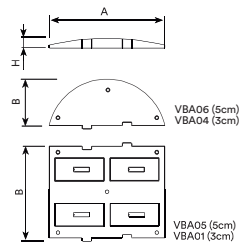

Slow

Conjunto de módulos independientes que forman una banda reductora de velocidad. Realizados en goma natural visible mediante franjas amarillas y negras paralelas a la dirección de la marcha, de elevada retroreflectancia y antideslizantes. Se adapta perfectamente al pavimento, absorbe deformaciones, no se dregrada ni se agrieta y no produce contaminación acústica. Reductor de velocidad de 30mm de altura para vías públicas con límite de velocidad máxima 50Km/h. Reductor de velocidad de 50mm de altura para vías públicas con límite de velocidad <50Km/h. Anclaje recomendado: Mediante 5 tornillos y anclaje plástico.

Ensemble modulaire d'éléments indépendants qui forment un ralentisseur de vitesse fabriqué en gomme naturelle, visible grâce à des bandes jaunes et noires parallèles à la direction de la circulation, hautement réfléchissantes et anti-dérapantes. S'adapte parfaitement au sol, absorbe les déformations, ne se dégrade pas, ne se fissure pas et ne crée pas de pollution acoustique. Ralentisseur de vitesse de 30mm de hauteur, pour les voies publiques où la vitesse est limitée à 50km/h maximum. Ralentisseur de vitesse de 50m de hauteur, pour les voies publiques où la limitation de vitesse est inférieure à 50km/h. Ancrage recommandé: Par 5 vis et un ancrage en plastique.

Modular set forming a speed-reducing band. Made of natural rubber with visible black and yellow stripes parallel to the direction of traffic. Highly retroreflective and non-skid. Adapts perfectly to the pavement, absorbs deformations, does not degrade or develop cracks; produces no noise pollution. 30mm speed bump for public thoroughfares with a speed limit of 50 km/h. 50mm speed bumps for public thoroughfares with a speed limit of <50km/h. Recommended anchoring: 5 bolts and plastic anchors.



VBA20

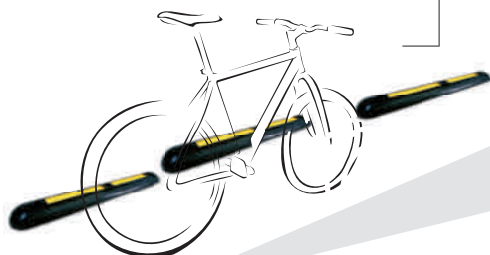

Vai

Realizados en goma natural visibles mediante franjas amarillas y negras paralelas a la dirección de la marcha, de elevada retroreflectancia y antideslizantes.

Fabriqués en gomme naturelle. Bandes jaunes et noires parallèles à la direction de la circulation, hautement réfléchissantes et anti-dérapantes.

Made of natural rubber with visible black and yellow stripes parallel to the direction of traffic. Highly retroreflective and non-skid.

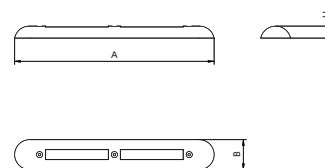

Ref.	A	B	H
VBA20	1000 mm	150 mm	60 mm

Contain

Acero inoxidable AISI-304. Anclaje: Mediante empotramiento en el suelo. Opcional: Acero zincado electrolítico con imprimación epoxi y pintura poliéster en polvo color gris RAL 9006 (CSS).

Acier inoxydable AISI-304. Installation: Par encastrement dans le sol. Optionnel: Acier zingué électrolytique, couche primaire époxy et hermolaquage polyester gris RAL 9006(CSS).

Stainless steel AISI-304. Anchorage: Embedded into the ground. Optional: Electro-galvanised iron with epoxy primer coating and a grey RAL 9006 polyester powder coated finish (CSS).



CSSI

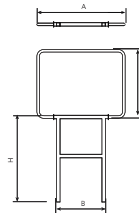

Ref.	A	B	H	H1
CSSI	1538 mm	850 mm	2708 mm	1198 mm
CSS	1538 mm	850 mm	2708 mm	1198 mm

Hide

Madera de pino con tratamiento autoclave a vacío-presión clase 4 contra la carcoma, termitas e insectos. Instalación: Mediante empotramiento de 400mm de los postes en el suelo. Opcional: Posibilidad de suministros adaptados a las necesidades del cliente. Sabías que... la madera natural "respira" es decir, absorbe y desprende la humedad en ambiente seco. Por lo tanto, es normal que puedan aparecer grietas en la madera. No influencia para nada en su capacidad de resistencia y su durabilidad. P. 10

Bois de pin traité en autoclave sous vide d'air classe 4 contre les vers à bois, les termites et les insectes. Installation : Par encastrement des poteaux de 400mm dans le sol. En option : Peut être adapté aux besoins du client. Saviez vous que... le bois naturel "respire", c'est-à-dire, qu'il absorbe et restitue de l'humidité dans une atmosphère sèche. Il est par conséquent normal que des fissures apparaissent dans le bois. Ceci n'influence en rien sa capacité de résistance et sa durabilité. P. 10

Pine wood vacuum-pressure treated in an autoclave (Class 4) against woodworm, termites and insects. Fitting: Posts embedded 400mm in the ground. Optional: May be customised to meet client requirements. Did you know... natural wood "breathes" i.e. it absorbs humidity and releases it in dry atmospheres. It is therefore normal for cracks to appear in wood. This has no effect whatsoever on its strength and durability. P. 10



VCC

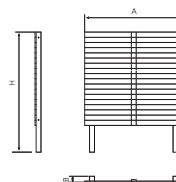

Ref.	A	B	H
VCC1	1800 mm	110 mm	2200 mm
VCC2	2100 mm	110 mm	2200 mm
VCC3	2400 mm	110 mm	2200 mm
VCC4	2600 mm	110 mm	2200 mm
VCC1L	1800 mm	110 mm	2200 mm

Mefa

Protector para farolas o arboles fabricado en acero zincado electrolítico. Acabado imprimación epoxi y pintura poliéster en polvo color gris RAL 7016.

Protecteur pour mâts ou arbres, fabriqué en acier zingué électrolytique. Finition couche primaire époxy et thermolaquage polyester gris RAL 7016. Ancrage : Scellé au sol.

Protector for poles or trees made of electrolytic zinc-coated steel. Epoxy primer and grey RAL 7016 polyester powder coated finish. Anchoring: Embedded.



VBZ01

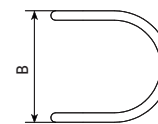
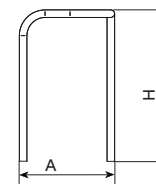

Ref.	A	B	H
VBZ01	630 mm	590 mm	1000 mm



La mejora y evolución constante de nuestros productos, puede provocar algunas modificaciones en las especificaciones técnicas y características de los mismos. Las características técnicas del presente catálogo tienen carácter vinculante salvo error u omisión. Los datos técnicos y normativas facilitados están basados en los conocimientos adquiridos y representan nuestra mejor experiencia para documentar al constructor sobre la aplicación de nuestros productos, pero no podemos responsabilizarnos de su mal uso, inadecuada ubicación e instalación, o falta de respeto a las Normas UNE EN 124, UNE EN 1176 y otras.

L'amélioration et l'évolution constante de nos produits peut engendrer certaines modifications dans les spécifications techniques et les caractéristiques de ces derniers. Les caractéristiques techniques du présent catalogue sont conformes sauf erreur ou omission. Les renseignements techniques et les normes fournis sont basés sur les connaissances acquises et représentent notre meilleure expérience pour informer le constructeur sur l'application de nos produits mais nous ne pouvons pas nous responsabiliser du mauvais usage, de l'emplacement ou de l'installation inappropriés ou du non-respect des normes UNE EN124, UNE EN 1176 entre autres.

The ongoing improvement of BENITO URBAN products can cause some modifications in its technical specifications and characteristics. The technical characteristics of this catalogue are binding except mistake or omission. Detailed technical data and rules are based on the acquired knowledge and represent our best experience to document the building company about our products application. However, BENITO URBAN cannot take responsibility of its wrong use, inappropriate location or installation, or non-respect towards European Standards EN 124, EN 1176 and others.

Cuidemos el medio ambiente. El contenido del presente catálogo está protegido en su totalidad por derechos de autor y copyright, quedando prohibida la reproducción total o parcial de las imágenes, textos, ilustraciones y conceptos gráficos sin la autorización de BENITO URBAN. Document non contractuel, BENITO URBAN se réserve le droit de modifier les caractéristiques sans préavis. Préservons l'environnement. Le contenu de ce document est protégé dans sa totalité par des droits d'auteur et copyright. Toute reproduction totale ou partielle des images, textes, illustrations et concepts graphiques est interdite sans l'autorisation de BENITO URBAN.

We respect the environment. The contents of this catalog are protected in their entirety by copyright and intellectual property rights. Reproduction, either full or partial, of the photos, text, illustrations and graphic concepts contained here is prohibited without authorization from BENITO URBAN.

BENITO

- Urban**
- Light**
- Play**
- Covers**

Lleida 10
08500 Vic Barcelona Spain
T +34 938 521 000
info@benito.com
www.benito.com

EUROPE

France +33 0 468 210 992
Portugal +35 1 308 802 832
Italy +39 02 89 877 711
Romania +40 318 110 991
Poland +48 223 971 508
Russia +7 499 504 28 76

ASIA

China +86 1063 705 530
Dubai +971 566 506 930
India +91 9560 695 254

AMERICA

Argentina +54 1 159 844 113
Chile +56 2 938 20 35
Mexico +52 5 546 319 722
Brazil +55 1 139 570 340
Peru +51 1707 1369
Usa +1 617 778 2947